

# VAC4 Hardware

## User Guide

An operating and troubleshooting guide for the Forklift Gateway (VAC), and other peripheral hardware (Some features require firmware from system release 08.05.00 or later).

## About this Guide

This Guide provides detailed information on the proper use and maintenance of Powerfleet Enterprise Material Handling Telematics Solution, including the 4th generation Forklift Gateway (VAC), and other vehicle peripheral hardware.

## Safety

The Powerfleet solution is not intended for use as a primary safety device. Installation must NOT adversely affect any vehicle safety system or safety device. The installation, configuration and operational procedures provided in this guide are intended for use ONLY by personnel certified on Powerfleet solution installation. It is the user's responsibility to ensure that the procedures in this guide are completed by certified personnel ONLY, using the proper tools and following the proper safety protocols. The procedures and recommendations in this guide do not supersede any Federal, State or Local regulations.

## Confidentiality Notice

© 2026 Powerfleet, Inc. All rights reserved. This document contains confidential and/or proprietary information and may be reproduced for the user's internal training purposes ONLY. This document may not be reproduced in part, or shown, or in any way disclosed to any third party, without the express written consent of Powerfleet, Inc.

## Disclaimer

The information contained in this Guide is subject to change without notice and should not be construed as a specification.

## Disclaimer and Limitation of Liability

Powerfleet, Inc. assumes no responsibility for any damage or loss resulting from the use of its products or services. Powerfleet assumes no responsibility for any loss or claims by third parties, which may arise through using its products or services.

# Table of Contents

<b>1</b>	<b>INTRODUCTION</b> .....	<b>6</b>
1.1	Related Documents .....	6
<b>2</b>	<b>SECTION 1: SYSTEM OVERVIEW</b> .....	<b>7</b>
2.1	Powerfleet Enterprise System Diagram .....	7
2.2	VAC Interface: LCD, Keypad, ID Reader, and LEDs .....	8
2.2.1	Status Indicators .....	8
2.3	Menu Screens .....	14
2.4	Data Input Screens .....	15
2.5	Multiple Choice Selection Screens.....	16
2.6	Login Methods (various methods are based on which version of Powerfleet is purchased) .....	16
2.6.1	Access IDs .....	17
<b>3</b>	<b>SECTION 2: CONFIGURING THE HARDWARE</b> .....	<b>17</b>
3.1	VAC Configuration .....	17
3.2	Wi-Fi Configuration on the VAC.....	18
3.3	Wirelessly receiving credentials from a nearby Wi-Fi-configured VAC.....	21
3.4	Receiving credentials from a Wireless Asset Manager (WAM) .....	23
3.5	VAC Synchronization.....	22
3.5.1	Wirelessly, using Intelligent RF (IRF) .....	25
3.5.2	Wirelessly, using Wi-Fi .....	22
3.6	Impact Sensor Configuration.....	22
3.7	Reading VAC “Info” Screens .....	24
<b>4</b>	<b>SECTION 3: STANDARD OPERATORS</b> .....	<b>28</b>
4.1	Logging into the VAC (to start the vehicle).....	28
4.2	Login Error Code Table [“Error (AXX)” plus below text when login is attempted].....	29
4.3	Reading VAC “About” Screens .....	30
4.4	Logging Off the VAC.....	32
4.5	Answering Safety Checklists.....	33
4.6	Critical Shutdown .....	34
4.7	<b>3.7 Operating the Vehicle</b> .....	<b>35</b>
4.7.1	Break Mode .....	35
4.7.2	Idle Timeout.....	36
4.7.3	Automatic Hibernate .....	36
4.7.4	Automatic Hibernate .....	38
4.7.5	Event Shutdowns (Impact, safety non-compliance, etc.) .....	37
4.7.6	Memory Status .....	37

<b>5</b>	<b>SECTION 4: MASTER OPERATORS (SUPERVISORS)</b> .....	<b>38</b>
5.1	Adding Temporary Users.....	38
5.2	Clearing Event Lockouts .....	40
5.3	Checklist Administration.....	40
5.4	Manual Vehicle Lock.....	41
5.5	Manual Vehicle Unlock .....	42
<b>6</b>	<b>SECTION 5: MAINTENANCE OPERATORS</b> .....	<b>43</b>
6.1	Installation and Configuration.....	43
6.2	ID Optional ('Soft' Bypass) .....	45
6.3	Read Operator Identification .....	47
6.4	Replacing an Existing VAC .....	48
6.5	Checking VAC Synchronization Status .....	50
6.6	Reset VAC Synchronization .....	51
6.7	Changing the VAC Facility ID .....	51
6.8	Forcing the VAC to Low Power Mode (Hibernate) .....	52
6.9	Checking VAC Internal Backup Battery (not applicable for all VAC types) .....	52
6.10	Changing the VAC Data Transmission Settings .....	53
6.11	Checking and Changing the VAC Usage Totals .....	54
6.12	Testing the BLU wire connection prior to VAC Configuration.....	55
6.13	Understand and Manually Set "Motion" for Electric Vehicles .....	56
6.14	Understand and Manually Set "Idling" for Internal Combustion Vehicles .....	57
6.15	Understand and Manually Set "Motion" for Internal Combustion Vehicles .....	59
6.16	Current VAC Configuration ("States" Screen).....	60
6.17	Last VAC Configuration ("InsReport" Screen) .....	62
6.18	Impact Sensor Troubleshooting .....	64
6.19	Manually Enabling Impact Calibration .....	66
6.20	Check Vehicle Battery Voltage Monitoring .....	66
<b>7</b>	<b>SECTION 6: WAM USE and TROUBLESHOOTING</b> .....	<b>69</b>
7.1	WAM Use.....	69
7.2	WAM LEDs Explained.....	69
7.3	WAM LEDs Explained.....	70
7.4	Cradlepoint Modem LEDs Explained.....	71
7.5	Modem Troubleshooting .....	71
<b>8</b>	<b>SECTION 7: VAC TROUBLESHOOTING</b> .....	<b>67</b>

8.1	Recommended maintenance tool list .....	67
8.2	VAC to Wired Vehicle Cable Pinout and Fuses .....	68
8.3	VAC Screen and LEDs do not Illuminate .....	68
<b>9</b>	<b>SECTION 8: SENSOR HUB ERRORS .....</b>	<b>69</b>
9.1	Pinout Diagram .....	69
9.2	Sensor Hub LED Indicators .....	69
9.3	Troubleshooting .....	69
<b>10</b>	<b>SECTION 9: SELF-DIAGNOSTIC ERROR CODES .....</b>	<b>70</b>
<b>11</b>	<b>SECTION 10: SYSTEM SUPPORT INFORMATION .....</b>	<b>99</b>
11.1	Technical Specifications – VAC4S and VAC4.....	99
<b>12</b>	<b>Appendix A: Customer Support and Return Merchandise Authorization (RMA) Policy &amp; Procedures.....</b>	<b>107</b>
12.1.1	Customer Support & RMA Information .....	107
12.1.2	RMA Procedure.....	107
<b>13</b>	<b>Appendix B (Hard Bypass Powerfleet access control) .....</b>	<b>109</b>
13.1.1	Refer to the Powerfleet Installation Guide for detailed wiring diagrams. ....	109
<b>14</b>	<b>Appendix C (Using the Powerfleet Wi-Fi Test Tool) .....</b>	<b>110</b>
14.1.1	POWERFLEET'S WI-FI TEST TOOL.....	110

# 1 INTRODUCTION

This Guide provides the information needed to configure, use, and maintain the hardware, including Powerfleet's Enterprise Material Handling Telematics Solution:

**VAC** Vehicle Asset Communicator

Related peripherals

In addition to this guide, Powerfleet offers many other ways to learn the system including but not limited to:

- Live training webinars
- Interactive self-paced learning modules
- How-to videos
- Technician Certification programs

## 1.1 Related Documents

This detailed Guide is a supplement to the following Powerfleet system documents:

Title	Description
<b>Powerfleet Enterprise Getting Started Guide</b>	General system instructions for the site coordinator.
<b>Powerfleet Enterprise Installation Guide</b>	Installation instructions for vehicle hardware.

**Note:** The VAC is an interactive minicomputer designed for installation on industrial vehicles. Since vehicle designs vary widely, this guide cannot provide precise instructions for each specific vehicle model. Instead, this guide provides the basic knowledge needed for a certified installer with a typical installation.

**Note:** The installation, configuration and operational procedures provided in this document are intended for use by authorized, certified personnel only. It is the responsibility of the supervisor to ensure that the procedures in this publication are only completed by trained/certified personnel, using the proper equipment, and following the proper safety protocols.

## 2 SECTION 1: SYSTEM OVERVIEW

### 2.1 Powerfleet Enterprise System Diagram



#### Placement of a VAC on a vehicle

- VAC must be mounted on the vehicle where it can be accessed by the operator without interfering with any vehicle operation.
- VAC interfaces with the vehicle for power, ignition/ access control, and usage monitoring using a supplied cable harness.
- VAC interfaces with operators through Access ID readers, LEDs, a keypad, and a backlit LCD display.
- VAC communicates automatically with remotely hosted software via Access Point, but operates seamlessly, even when not in coverage range.

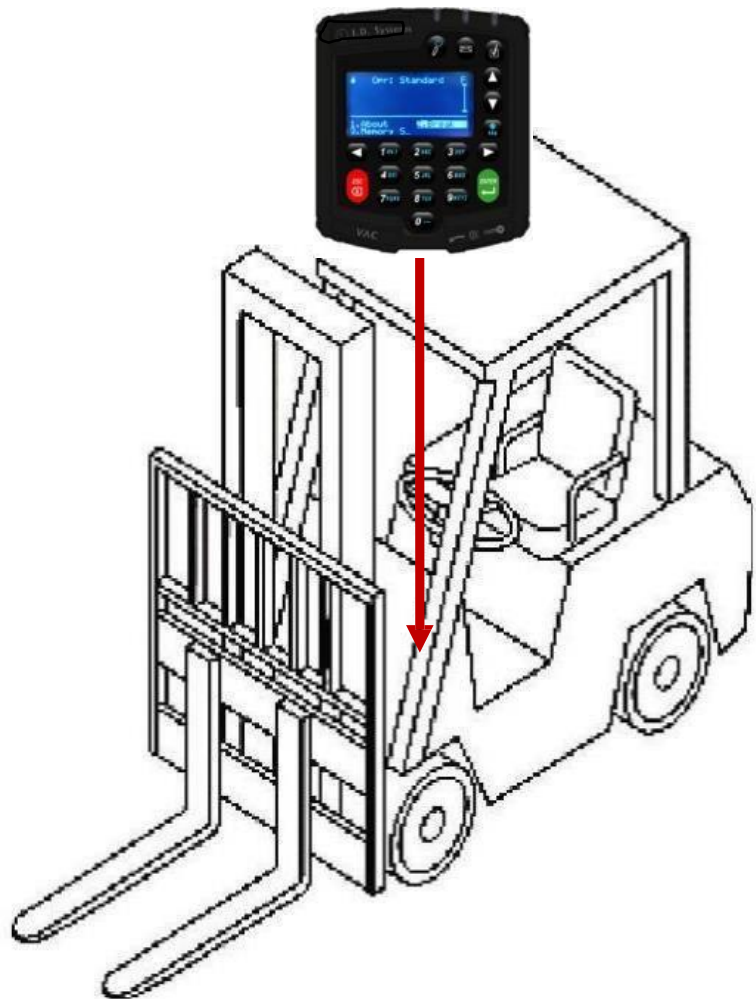

## 2.2 VAC Interface: LCD, Keypad, ID Reader, and LEDs

The VAC incorporates a 20-key keypad that is easy to read and operate.

The graphical LCD screen remains backlit for 15 seconds after any key is pressed on the keypad.

The VAC identification reader for vehicle access control. Operators use individual access identification “keys” to the vehicle. (i.e., iButton fobs, prox cards, etc.).



Vehicle keys may still be required, depending on wiring and can be safely left in the vehicle.



### 2.2.1 Status Indicators

When the VAC is powered, the VAC has three integrated LEDs for operator and supervisor status indication.







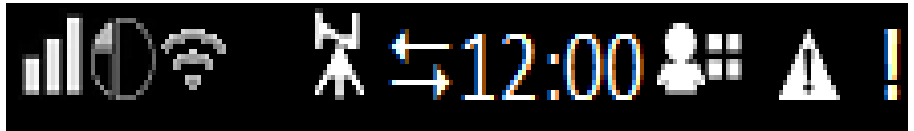

LED	Message	LED State	Indication
	Access	Off	No one logged in and the vehicle is in Registered ID or Any ID mode (operators must log in to operate the vehicle).
		Blinking Green	No one logged in and the vehicle is in ID Optional mode (anyone can use the vehicle without logging in).
		Solid Green	An operator is logged in (the vehicle should NOT be left unattended in this state).







		Blinking Green/Orange	The vehicle is locked or about to be locked for certain operator levels (as a result of a vehicle impact or other event).
	<b>Message</b>	Off	There are no incomplete tasks, no unread text messages, and no active errors.
		Blinking Red	The vehicle has an unread message, task, or an active diagnostic error.
	<b>Checklist</b>	Off	No one logged in and/or the vehicle is compliant for all configured checklists.
		Blinking Yellow	There is a checklist that needs to be completed.

**Note:** When the Access, Message, and Checklist LEDs blink in sequence, the VAC is in 'programming' mode and cannot be used by operators. Call Powerfleet's Support if this condition persists for more than twenty-five minutes.

The VAC screen displays the current time and status icons (top row). Status icons are:









Icon	Meaning	Indication
	Reception Bars	Reception bars provide an indication of signal strength the VAC is currently experiencing for the wireless communication method which is affected by the proximity to nearby WAMs or AP's. (X without bars = no coverage, 1 bar = weakest, 3 bars = strongest)
	IRF Communication	Indicates the VAC is ready to use or is using Intelligent RF (IRF) to communicate with the system. If inverted, the VAC has data to send to a WAM but is unable to do so using IRF. IRF is a proprietary 868/915 MHz technology. Refer to reception bars to determine communication strength.
	Wi-Fi Communication	Wi-Fi communication icon indicates that the VAC is ready to use or is using Wi-Fi to communicate with the server. If inverted, the VAC has data to send to the server but is unable to do so using Wi-Fi. Refer to the reception bars to determine the strength of the communication.
	GPS Triangulation	GPS triangulation icon indicates that the VAC has triangulated its location with GPS satellites. Direction is found through this navigational aid.
	OEM CAN Communication	OEM CAN communication icon indicates that the VAC is configured to communicate with a CAN equipped vehicle. If only the arrow pointed to the right  is visible, the VAC has not recently received data from the CAN (such as when the key is off). If only the arrow pointed to the left  is visible, communication with the CAN is failing.
	Time Clock	The time clock (bracketed) indicates the current local time (24-hour clock format). The time is replaced by a countdown when a safety checklist is required. If the time is blank [     ], the VAC does not yet know the local time zone (i.e. first installed and yet to communicate to the system).
	Logged-in Operator Level	Indicators are inverted icons (black on white) when the operator is not recognized in the system software (i.e. new IDs in "Any ID" mode)

	Operator - 1 box	STANDARD	Standard operator logged in.
	Operator- 2 boxes	MASTER	Master operator logged in.
	Operator- 3 boxes	MAINTENANCE	Maintenance operator logged in.
	Operator- 4 boxes	ADMINISTRATION	Administrator logged in (Powerfleet use only).
	Operator- IT	IT	An IT operator logged in.
	Diagnostic Error	<p>The Diagnostic Error icon is accompanied by a flashing red LED on top of the VAC. At least one <b>REFERENCE</b> or <b>FUNCTIONAL</b> diagnostic error (i.e. Impact sensor error) is active on the vehicle. However, these errors Do Not lock the vehicle or prevent operator use of the VAC.</p>	
	Diagnostic Error (Lockout)	<p>Is accompanied by a flashing red LED on top of the VAC. The vehicle is <b>Locked Out</b> for all operators except Maintenance users. At least one <b>SAFETY/ SHUTDOWN</b> diagnostic error (i.e. Vehicle not correctly configured for motion) is active on the vehicle and there is a driver safety risk.</p>	

The VAC indicates different vehicle and solution conditions in the main screen using text as well as iconography (some with animation). Common icons include the following:

Icon	Meaning	Indication
	<b>Battery</b>	(hourglass icon) New battery request is being processed.
	<b>Break</b>	(clock icon) The vehicle is in Break mode. This feature is used to keep the vehicle from being borrowed during short breaks. The break time is typically 15 minutes. The one operator sets the vehicle in Break mode and only a Master operator or a Maintenance operator can log in until the Break time expires.
	<b>Checklist</b>	<p>(check icon) The Checklist icon is accompanied by a blinking yellow indicator LED. The checklist icon is also sometimes accompanied by a grace period timer  indicating how long (in minutes) before a non-compliance event is created.</p> <p>The same countdown will also appear in the Status Header. The vehicle has an active checklist that requires a Standard operator to complete.</p>
	<b>Diagnostics</b>	<p>The blinking Diagnostic icon is accompanied by a blinking red LED.</p> <p>The vehicle has active Diagnostic errors. A Maintenance operator must correct and clear the error, or, in some cases, the error will clear itself.</p> <p>See section 7, VAC Troubleshooting, for more details on diagnostic errors.</p>
	<b>GPS</b>	<p>When the GPS icon is displayed, the vehicle cannot determine location using the GPS sensor.</p> <p>Make sure the GPS sensor is connected and configured properly and that the GPS receiver has a clear line of site to a satellite symbol.</p>
	<b>Impact</b>	<p>The Impact icon is accompanied by a blinking yellow indicator LED.</p> <p>The vehicle has an active impact event. When displayed on its own, the impact event did not result in a lockout and standard operator feedback is required by completing a checklist.</p>

	<b>Lockout</b>	The Lockout icon is accompanied by an alternating, blinking Green/ Orange LEDs. The vehicle is locked and can only be logged into using Master or Maintenance operator credentials.
	<b>Low Battery</b>	(Battery icon) The vehicle battery is low and requires a charge.
	<b>Low Oil Pressure or High Engine Temperature</b>	(engine icon) The oil pressure or engine temperature inputs (VIMs 10 and 11) are outside the normal range. Check the engine for low oil or coolant.
	<b>Maintenance</b>	(wrench icon) Accompanied by alternating, blinking Green/ Orange LEDs. The vehicle is locked and can only be logged into using a Maintenance operator credentials.
	<b>Master</b>	(person icon) The Master icon is accompanied by a blinking yellow LED. The vehicle has an active checklist that requires a Master or Maintenance operator to complete.
	<b>New Message</b>	(envelope icon) The New Message icon is accompanied by a blinking red LED. A new message was received for the vehicle and/or operator. Once the message is read, the icon disappears.
	<b>Pedestrian Proximity Detection</b>	(waves icon) The Pedestrian Proximity Detection has detected a breach in the direction of travel of the vehicle.
	<b>Shield</b>	(shield icon) The vehicle is in Emergency Access mode, indicating that any operator can access and operate the vehicle without logging in through the VAC.
	<b>Speeding</b>	(speeding sign icon) The operator was driving over the configured speed limit. The icon will disappear once the vehicle decelerates to an acceptable speed level.
	<b>Zone</b>	(do not enter icon) The operator has driven the vehicle inside a restricted area. Drive the vehicle out of the restricted area to clear the icon.

## 2.3 Menu Screens

The Menu screens allow the operator to read and scroll through multiple lines of text as well as rapidly scan through and select the menu item of choice.





**Quick press:** Highlights menu option corresponding to key pressed, then ENTER must be pressed to make the selection.

**Long press:** Press and hold on the number keys that corresponds to the menu option advances to the next screen, without pressing ENTER.

The following is an example of the Quick Press or Long Press feature:

-  Press and **HOLD** the 2 button for more than 2 seconds to highlight the menu option. Select 2. OK to advance to the next screen.
 

~ OR ~
-  Press the right arrow button to move the highlighted selection from: Select 1. UPDATE  
Select 2. OK  
Then press ENTER.
 

~ OR ~
-  Press the 2 button to highlight Select 2. OK. Then press ENTER.

## 2.4 Data Input Screens

Data input screens allow the operator to enter data when prompted by the VAC system.

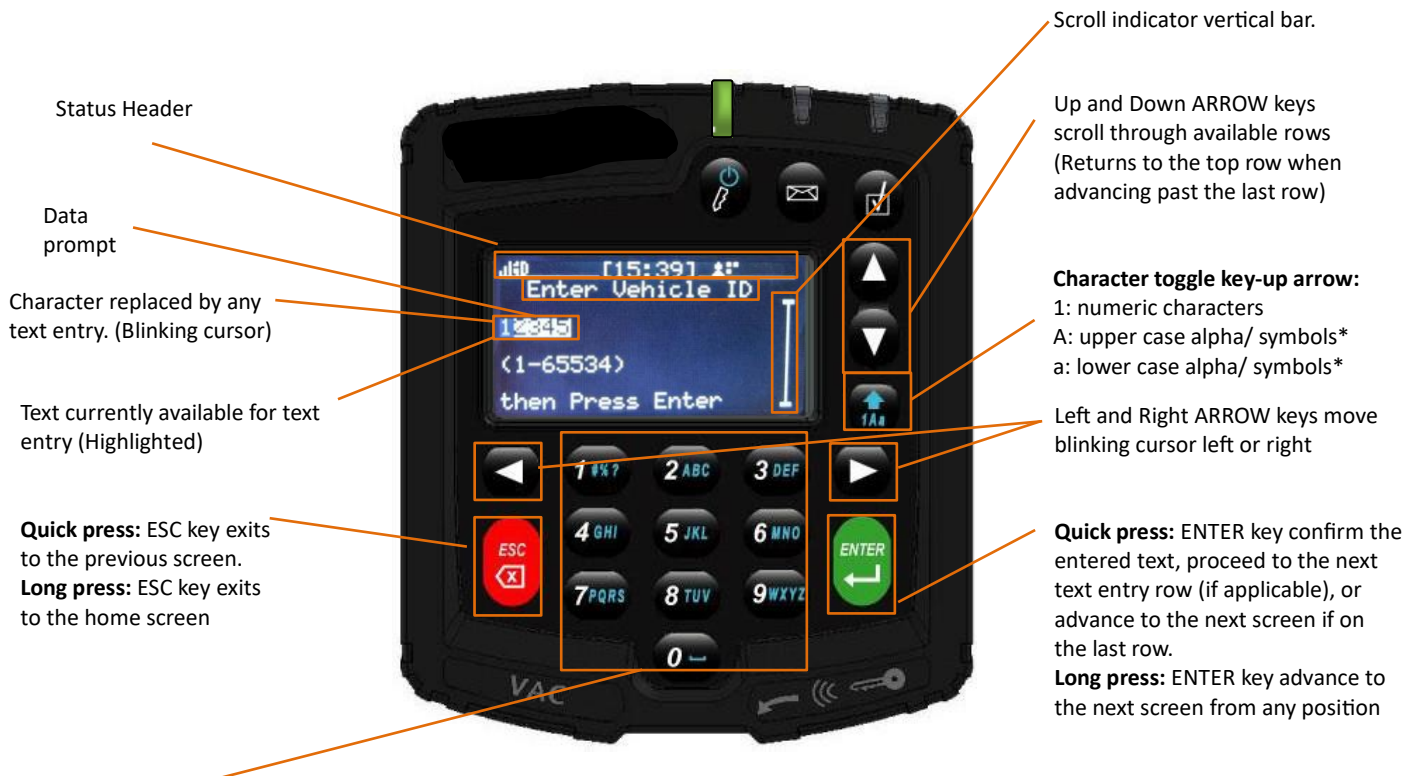

Enter alphanumeric characters in the currently selected mode.  
 (Cursor **auto-advances** one character if no key is pressed for **more than 1 second**) (Cursor **auto-advances** one character if a **different key** is pressed than the previous)

\* Common symbols used during text entry are as follows:

- 0 = [space] when not in numeric entry mode.
- 1 = symbols when not in numeric entry mode.

Mode	Symbols
<b>a (lower case) mode</b>	= + - * / ( ) { } [ ] % < >
<b>A (upper case) mode</b>	? , @ ! : . # _ \ & “ ‘ ; ^   \$ ~

## 2.5 Multiple Choice Selection Screens

Multiple choice selection screens allow the operator to pick one item from a list which is like a pick list.



## 2.6 Access IDs

**Note:** Access IDs are often provided by the end user.



When the system is in “Any ID” access mode (default configuration when the VAC is shipped), an access ID creates a “Place Holder” operator profile in the Powerfleet Vision Pro software when first presented to a VAC and the operator is granted access to the vehicle as a **Standard** operator.

The place holder profiles are associated with the ID’s embedded identification number and can be updated with actual operator information (name, password, authorization level, etc.) at the customer’s discretion.

Alternatively, operator profiles can be added directly to the software (in “Any ID” mode or “Registered ID” mode) by presenting the access IDs to the desktop Access ID Reader. Refer to the Powerfleet Vision Pro training video for more details.

To access the vehicle as a **Master or Maintenance** level operator, the numeric operator ID and password using the VAC keypad must be entered. The ID numbers can be found in the installation documentation. The software should be used to assign individuals’ IDs as Master or Maintenance operators.

## 3 SECTION 2: CONFIGURING THE HARDWARE

### 3.1 VAC Configuration

A VAC equipped vehicle cannot be used by the Standard or Master operators until the VAC has been successfully configured by a Maintenance operator for the BASIC configuration wizard.

The VAC on-screen message and blinking red LED is displayed. (Note: instructions for testing the BLU wire connection prior to VAC configuration are in Section 5).

Once the Powerfleet Enterprise vehicle hardware has been properly installed, the vehicle can only be accessed using the yellow maintenance IDs, or a Maintenance level operator login.

When a Maintenance operator logs in, they will be required to follow a series of VAC screen display instructions displayed to verify the installation and configuration.

**This process time is about 3 to 5 minutes and requires the operator to perform the following:**

1. Enter or confirm the Facility ID. This number is unique to the facility where your system is operating. For VACs in your facility with the incorrect Facility ID, there will be no communication to the system infrastructure.
  - a. Your facility ID was communicated to the system coordinator with your software access credentials.
  - b. If you enter a zero on the facility ID screen, the VACs will assign the facility ID of the first WAM it communicates with (while on the facility ID screen).
  - c. If you do not know the facility ID, contact Powerfleet's Support.
2. Enter or confirm your license key (based on features purchased).
  - a. License key was communicated to the system coordinator with the assigned software access credentials.
  - b. If you do not know the facility ID, contact Powerfleet's Support.
3. Select vehicle type:

FR	Forklift Rider	OP	Order Picker	SE	Sweeper	TR	Turret Truck
FS	Forklift Stand-up	PC	Preconditioned Air	SR	Stacker Rider	TT	Tow Tractor
GP	Ground Power Unit	PR	Pallet Jack Rider	SW	Stacker Walkie	TV	Truck/ Van
JB	Jet Bridge	PW	Pallet Jack Walkie	TH	Other		
ML	Man Lift	RT	Reach Truck	TL	Towbarless Tow		

4. Enter the vehicle label number. The numeric value is between 1 and 65534.
5. Select a vehicle Engine Type (VDI CAN interface VACs skip steps 5-7 and drive tests):

Electric	Electric motor	Gas/IC	Internal combustion	iPort	iPort enabled electric
----------	----------------	--------	---------------------	-------	------------------------

6. Select what the Green and Yellow wires are connected to for access control:

On/Off Relay	Relay supplied with kit	Vehicle PWM Circuit	Connected to vehicle circuit with PWM
--------------	-------------------------	---------------------	---------------------------------------

7. For Electric vehicles, select the BLU wire input type (where the BLU wire was connected to):

V (Avg)	Voltage average mode	V (min/max)	Voltage minimum/maximum mode
---------	----------------------	-------------	------------------------------

8. Follow the VAC Configuration Wizard’s VAC screen display prompts for performing vehicle actions (i.e., start vehicle, release brake, drive forward, drive in reverse, etc.)

Once the VAC has been configured without errors, the VAC is active in “Any ID” mode and any hardware-compatible ID can access the vehicle. In Any ID mode, the system will NOT lock out vehicles due to impacts, critical checklist responses, etc. If you are unsure which mode the system is in, check the operator icon in the header of the VAC screen when logged in or Maintenance operators can determine the current VAC mode using the Access menu. (Any ID mode has the icon color inverted) (See ‘ID Optional’ in Section 5: Maintenance Operators for more details).



**Note:** If the configuration fails and an error message is displayed, refer to Section 7: VAC Troubleshooting. After the “BASIC” wizard is complete, continue to the “SENSOR” wizard. Refer to the VAC installation Guide for more details on sensor configuration.

### 3.2 Wi-Fi Configuration on the VAC

PRIOR TO CONFIGURING VACS FOR YOUR WI-FI SYSTEM, VALIDATE YOUR NETWORK CONFIGURATION WITH [POWERFLEET’S WI-FI TEST TOOL](#).

THERE ARE TWO TEST TOOLS AVAILABLE. THE SMART PHONE APP (SEARCH "VMS TOOLS" IN THE ITUNES OR GOOGLE PLAY APP STORES) IS THE PREFERRED METHOD. A PC-BASED VERSION IS ALSO AVAILABLE THROUGH THE LINK SUPPLIED IN APPENIX C (or email support@powerfleet.com).

VACs equipped with Wi-Fi can be configured with the desired Wi-Fi security credentials and server information any time the VAC is powered. There are four ways Wi-Fi credentials can be applied:

- Entering credentials on the VAC using the keypad.
- Wirelessly receiving credentials from a nearby Wi-Fi-configured VAC.

### Entering credentials on the VAC using the keypad

1. Log into the VAC as a Maintenance operator or IT operator.
2. From the VAC main menu screen, Select Wi-Fi.



3. If the VAC is in range of wireless networks, a list will appear on the VAC screen. Otherwise, OFF is displayed.
4. The VAC's default Wi-Fi configuration uses DHCP.
  - a. To configure the VAC using DHCP, skip to step 6.
  - b. To configure the VAC to use a Static IP address, complete step 5.
5. From the VAC menu screen, select VAC IP. Select STATIC. When prompted, enter the requested IP, Subnet Mask, and Default Gateway values. Use leading zeros as appropriate (For example, if the IP Address is "150.215.17.9" the value entered in the VAC should be "150.215.017.009"). After providing the requested Static IP values, press ENTER to proceed to the next screen.
6. To identify the Server to connect with, VAC menu screen, select SERVER IP. Select the server IP 'type' (Static IP or Domain Name), then type in the prompted data using either the Server IP or Domain Name. In both cases, the Server Port must be entered, and a selection made for TLS encryption (TLS encryption or Proprietary as coincides with your software). For PWFL-hosted systems, this information is provided by Powerfleet.

**Note:** If steps 4 through 6 are not performed in the proper order, the VAC will not connect to the server of access point.

7. From the VAC menu screen, select CONNECT.

8. Connect to the facility's wireless network.
  - a. If the VAC display lists the desired SSID, use the up and down scroll arrows keys to select the desired SSID from the list.

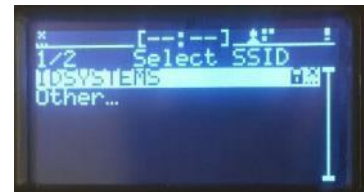

9. Enter the Key for Wi-Fi Credentials.



- i. Press ENTER.
- ii. Enter the credentials for the selected SSID in the locations provided. Use the navigation arrows to skip to different areas of the text entry boxes.

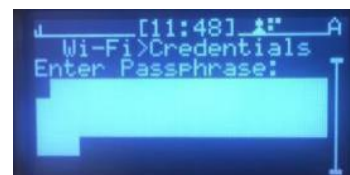

**Note:** For WEP credentials, 10 or 26 HEX (0-9;A-F) characters must be entered (ASCII entry not permitted).

- iii. Press ENTER.
- iv. The VAC will automatically attempt to connect to the selected SSID using the credentials provided.

- b. If the VAC display does not list the desired SSID, select OTHER. Press ENTER.
  - i. Using the VAC keypad, manually enter the SSID.



- ii. Select the security method that corresponds with the SSID.



- iii. Enter the credentials for the SSID.



**Note:** For WEP credentials, 10 or 26 HEX (0-9; A-F) characters must be entered (ASCII entry not permitted).

iv. The VAC will automatically attempt to connect to the SSID using the credentials provided.

**Note:** To successfully connect, the VAC must be within wireless communication range of the SSID.

9. Once connected, the VAC screen displays the Wi-Fi status indicator.



10. For instructions on how to broadcast the VAC's Wi-Fi credentials to nearby VACs that have not been configured, refer to the next section: **Wirelessly receiving credentials from a nearby Wi-Fi-configured VAC.**

### 3.3 Wirelessly receiving credentials from a nearby Wi-Fi-configured VAC

1. Select a VAC that has been configured with the desired Wi-Fi profile.
2. Log into the VAC as a Maintenance operator or IT operator.
3. From the VAC main menu screen, select Wi-Fi.



- a. To broadcast the VAC's Wi-Fi configuration to other VACs, select TRANSMIT.



- b. To confirm broadcast of the VAC's Wi-Fi configuration, select YES.

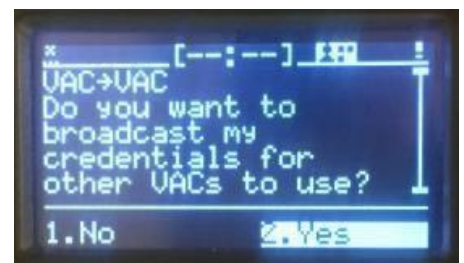

The VAC will return to the main Wi-Fi screen.

A “Share” icon will appear to the right of the SSID name.



- For the next 24 hours, that VAC will transmit its Wi-Fi profile to any VAC that comes within wireless communication range.
- All Wi-Fi profile components (SSID, credentials, server IP/ port, etc.) are transmitted.
- VACs must be configured with the same facility code and RF frequency to successfully send and receive a transmitted Wi-Fi profile.
- Recipient VACs must be within wireless range of the sending VAC for approximately 1 minute to receive the transmitted Wi-Fi profile.
- Depending on obstructions and environment, the average wireless sharing range is 500 feet.
- The VAC will automatically begin trying to connect with the newly received profile once a recipient VAC receives the credentials.
- To force the VAC to stop transmitting, from the main Wi-Fi menu option, select STOP TRANSMIT. Otherwise, the VAC will stop transmitting on its own after 24 hours.
- The VAC will only transmit credentials typed into it, or received from another VAC. It will not transmit credentials synchronized from the software nor enterprise certificates.

## 3.4 VAC Synchronization

### 3.4.1 Wirelessly, using Wi-Fi

When a successfully configured VAC (including Wi-Fi profiles; see “Wi-Fi Configuration on the VAC”) comes within wireless coverage range of a working and valid Access Point, the VAC will automatically synchronize its configuration with the Vision Pro software. The first synchronization may take 5-10 minutes, depending on the number of changes (added operators, groups, etc.) made in the Vision Pro software. Subsequent synchronizations may take from a few seconds to a minute.

## 3.5 Impact Sensor Configuration

There are 3 steps to achieving a functional impact management system once the impact sensor is properly physically installed.

Refer to the Powerfleet Installation Guide. Each step is automatic and designed to work out-of-the-box.

The **first step** is calibrating the impact sensor, which relies on proper installation and mounting. The purpose of the calibration is similar to resetting an empty scale to zero pounds before weighing an object. A valid reference point is needed. The calibration process is automatically performed during the VAC Configuration process above.

Once that process is completed without errors, the impact sensor has its initial calibration. The system then automatically re-calibrates the sensor once per day during periods of inactivity to make sure the environment hasn't changed (i.e., the sensor came loose from the mounting surface).

If a subsequent calibration attempt fails, a diagnostic error is reported.

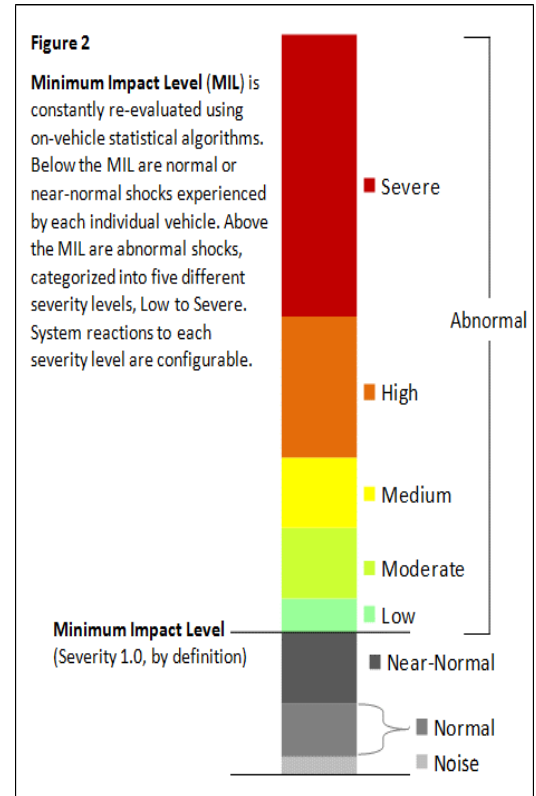

The **second step** is determining a valid Minimum Impact Level (MIL) Threshold. The MIL quantifies the point between “normal” and “abnormal” shock activity on each individual vehicle and forms the basis for defining the relative severity of abnormal impacts. The MIL is an automatically calculated point, based on continuous evaluation of real-time impact data, which adjusts automatically to reflect the actual range of “normal” shock activity on each vehicle as it changes over time (due to different drivers, environments, tasks, etc.).

The MIL is assigned a Severity Level of 1.0, no matter how its calculated value fluctuates. Below this level, shock activity is classified as Normal, Near-Normal, or simply Noise, and is not recorded in detail. Above the MIL, impacts are classified as Abnormal and recorded in five Severity Levels (Low, Moderate, Medium, High, and Severe). Each Severity Level is defined by its relative order of magnitude above the baseline MIL of 1.0.

The initial MIL is often determined within an hour of driving a vehicle. The continuous auto-adjustments to the MIL Threshold take place virtually instantaneously, so the system adapts very quickly to changes in a vehicle’s operating environment and driver’s behavior. No operator effort is required to configure the MIL and have the impact sensor begin functioning properly.

The **third step** is fine tuning the preconfigured severity levels based on your site’s impact behavior goals.

The default impact Severity Levels are:

**Low < 1.6    Moderate .6 to < 2.1    Medium 2.1 to < 5.1    High 5.1 to < 8.1    Severe ≥ 8.1**

Certain software roles allow you to change the default. The default system reactions to impacts are:

Impact Level	Description
<b>Low Impact and Moderate Impacts</b>	The VAC will store and report event details about without taking any on-vehicle actions.
<b>Medium Impact</b>	The VAC will flash an LED and prompt the operator to complete a self-inspection checklist to identify injuries or damage.
<b>High Impact and Severe Impact</b>	The VAC will lock out the vehicle (after a warning and grace period to bring the vehicle to a stop) and require a Master or Maintenance operator to log in and complete a supervisor checklist to release the vehicle.

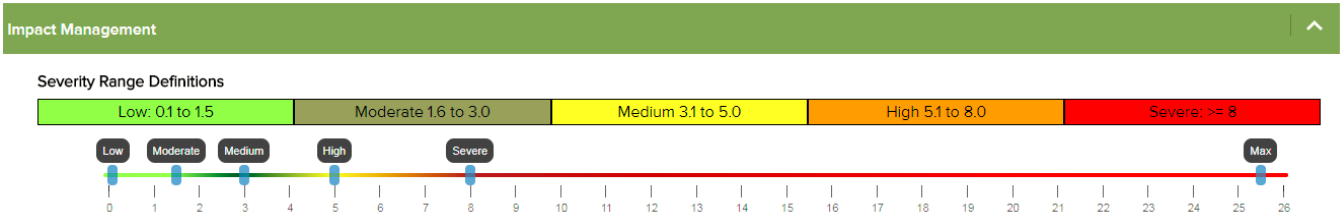

The system defaults to recommended settings for impact severities. However, to provide end users flexibility of use, each Impact Severity Level can be adjusted in the Powerfleet Vision Pro software. Select the Edit icon (the Edit button in the bottom of the screen).

Impact Severity Levels may need to be manually adjusted if, for example, a vehicle is experiencing many Medium impacts, but operators are not reporting any damage on the self-inspection checklists triggered by those impacts. In this example, one might want to increase the Medium slider setting from 2.1 to 3.0 or 3.5. An impact would then have to be harsher to qualify as Medium. This would result in fewer Medium impacts, but a greater proportion of the Medium impacts would result in damage that would be reported on the Medium impact checklists.

### 3.6 Reading VAC "Info" Screens



Screen Display  
(first page)  
Without logging in  
with an ID and  
password,

Select INFO

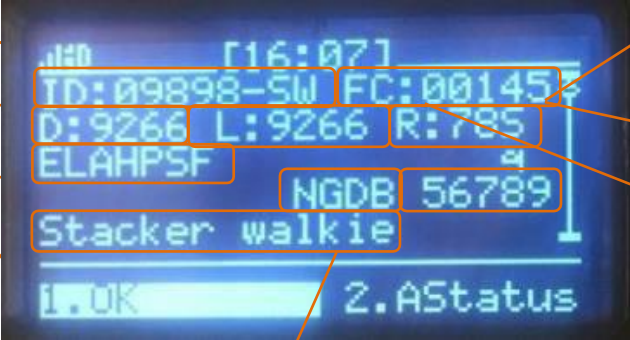

**ID:** Vehicle ID

**D:** IRF frequency for VMS data

Sync Segment Quick Status (one letter per 'segment') Lowercase: received; NOT synchronized;

**UPPERCASE:** synchronized (see VAC Synchronization Status section)

**FC:** Facility ID (or facility name code once synchronized)

**R:** IRF data rate

Site Code

Customer code

Configured vehicle type and ID

Screen content: [16:07] ID: 09898-SW FC: 001457 D: 9266 L: 9266 R: 785 ELAHPST NGDB 56789 Stackertype walkie [UK] 2.AStatus

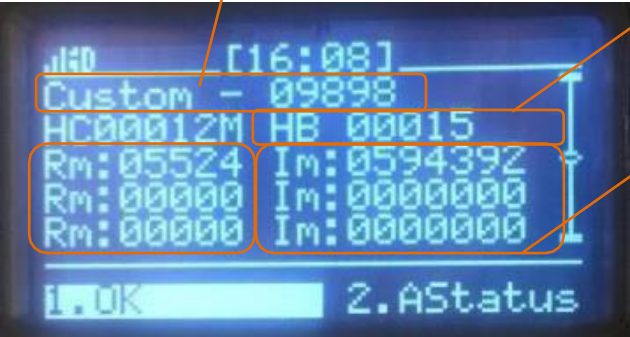

**HC:** Automatic hibernate countdown (minutes remaining)

**RM:** Firmware packets remaining to download for upgrade.

**HB:** Automatic hibernate setting (minutes)

**IM:** Firmware upgrade image size in bytes (100 bytes per packet)

Configured vehicle type and ID

Screen content: [16:08] Custom - 09898 HC00012M HB 00015 Rm: 05524 Im: 0594392 Rm: 00000 Im: 0000000 Rm: 00000 Im: 0000000 [UK] 2.AStatus

Screen Display:

(scroll down to the second page)



L	DB firmware upgrade status
0-0	No firmware to download or install
0-1	Firmware install pending
1-0	Firmware downloading
2-0	Firmware pending download
3-1	Fully downloaded, pending installation

S	Overall firmware upgrade state
A9,B9,E9,F9	VAC can program available firmware
00,02,08,10,12,18,20,22,28,30,32,38,40, 42,48,50,52,58,60,62,68,70,72,78,80, 82,88,90,92,98,1A,2A,3A,4A,5A,6A, 7A,8A,9A,0A,A0,A2,A8,AA,B0,B2,B8, BA,C0,C2,C8,CA,D0,D2,D8,DA,E0,E2, E8,EA,F0,F2,F8,FA	VAC can only program available firmware by a request from an authorized operator
09,19,29,39,49,59,69,79,89,99,C9,D9	VAC can only program available DB firmware
03,13,23,33,43,53,63,73,83,93,1B,2B,3B, 4B,5B,6B,7B,8B,9B,A3, AB,B,B3,BB,C3, CB,D3,DB,E3,EB,F3,FB	VAC cannot program any firmware because VAC is in ID Optional mode

P	(1st 2 digits): PIB firmware upgrade status
0-0	No firmware to download or install
0-1	Firmware installs pending
1-0	Firmware downloading
2-0	Firmware pending download
3-1	Fully downloaded, pending installation

P	(2nd 2 digits): Firmware upgrade priority
00, 02, 10, 12	PIB is currently highest priority
01, 03	DB is currently highest priority
11	SH is currently highest priority

**Note:** Other combinations are possible, contact Powerfleet Support for more details.

## 4 SECTION 3: STANDARD OPERATORS

### 4.1 Logging into the VAC (to start the vehicle)

- 1 If the VAC screen is blank, press the VAC's POWER button  and turn the vehicle ignition key to the on position.

Note: If the VAC is on an internal combustion (IC) vehicle that has not been used for 35 minutes (configurable), the VAC will go into Power Down Mode, and the VAC screen will be blank. If this is the case, the

VAC's POWER button  must be pressed, or the vehicle's ignition key must be turned on to power the VAC back up.

- 2 When the initial VAC login screen is displayed, touch a form of login credential (iButton fob or Access ID) to the reader.

**Note:** If a PIN password is also required for login, the VAC screen will prompt the operator to enter the PIN number. Press the numeric keys to enter the PIN (displayed as asterisk: \*\*\*\* for security). Press ENTER.

- 3 If the access ID is authorized for that vehicle, the vehicle will start, and the VAC's green LED will turn on. If a safety checklist has not been completed for the vehicle within the compliance period (default is set to 14 hours), the checklist automatically begins when the operator logs in. The VAC's yellow LED blinks and the operator has 20 minutes of login time to complete the checklist. (The time left to complete the checklist is displayed in the status header of the VAC screen). If the operator exits the checklist without completing it, the operator is automatically logged off the vehicle. If the 20-minute grace period expires, the operator is prompted that a lockout will occur, and the VAC displays a countdown to the lockout.

For safety reasons, when an operator is logged into the VAC and the vehicle is in motion, the keypad will be inoperative. Once the vehicle comes to a complete stop, the VAC keypad will again be operable, and the screen will illuminate.

**Note:** In "Any ID" mode the vehicle will NOT lock after the checklist grace period if the checklist is not completed.

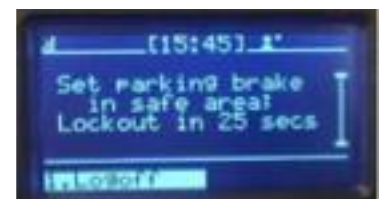
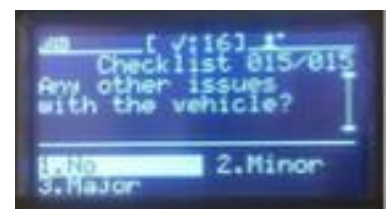

## 4.2 Login Error Code Table [“Error (AXX)” plus below text when login is attempted]

Code	Display Text	Possible Cause	Solution
A03	Not authorized for this vehicle	The operator is not authorized in the system software for that vehicle.	A Master or Maintenance operator can add this operator using the “Temp Users” menu option (See Section 3).
A04	Invalid operator ID or password	PIN password does not match the operator ID in system software.	A System Administrator can reset or eliminate the PIN password in the system software.
A05	Invalid operator ID or password	Operator authorization is expired for that vehicle group, or the operator’s medical, training, or certification date has expired.	A System Administrator can reset the authorization in the system software. However, a Master operator cannot add this driver using the “Temp Users” menu option.
A06	Present electronic ID	Operator attempts VAC login using the keypad instead of the integrated Access ID reader.	The operator must log in with an acceptable login method (iButton fob or Access ID).
A07	Critical response lockout	The vehicle is disabled for Standard operators due to a “Critical” safety checklist response.	A Maintenance operator must log in to unlock the vehicle.
A08	Present electronic ID	Operator attempts VAC login with a manual code reserved for certified installers. These codes are automatically disabled after installation.	The operator must log in with an acceptable login method (iButton fob or Access ID).
A09	Vehicle not authorized for use	The vehicle is taken out of service via the system software, or the vehicle does not belong to any group with valid authorization expiration.	A System Administrator can put the vehicle back into service or reset the group authorization in the system software.
A11	Security shutdown	The vehicle is deactivated by a system administrator via the system software.	A System Administrator can reactivate the vehicle in the system software.
A13	Vehicle is in break mode, cannot login	The vehicle is locked by its previous operator.	The vehicle can be unlocked by (1) the previous operator logging out, (2) a Master or Maintenance operator logging in, or (3) the break period expiring (15 minutes).
A14	Master lockout, cannot log in	The vehicle is locked by a Master operator.	A Master or Maintenance operator must log in to unlock the vehicle for Standard operators.
A15	Vehicle locked due to lockout event	The vehicle is locked due to an impact or checklist non-compliance event.	A Master or Maintenance operator must log in to unlock the vehicle for Standard operators.
A16	Maintenance lockout, cannot log in	The vehicle is locked by a Maintenance operator.	A Maintenance operator must log in to unlock the vehicle for Standard operators.

A17	<b>Vehicle locked due to lockout event</b>	The vehicle is locked due to a checklist critical response.	A Maintenance operator must log in to Unlock the vehicle for Standard operators.
A18	<b>Checklist timeout, cannot log in</b>	The vehicle is locked due to a checklist non-compliance event.	A Maintenance operator must log in to unlock the vehicle for Standard operators.
A19	<b>System error cannot log in</b>	The vehicle is locked due to a system error that must be cleared.	A Maintenance operator must log in to release the vehicle for Standard operators.

### 4.3 Reading VAC "About" Screens

The VAC's "About" screen displays identifying information about the VAC's current operator, registered license key, and system release version.

To access the "About" screen from the VAC's main login screen, select ABOUT.

Currently logged in operator type (and ID number for non-keypad operators).



<p><b>v</b> Release version</p> <p><b>LP</b> Troubleshooting Information</p> <p><b>Opr</b> Operator type</p> <p>Installed Firmware status</p>		<p><b>(c)</b> Release year</p> <p><b>LE</b> Troubleshooting Information</p> <p><b>LR</b> Troubleshooting Information</p>
<p><b>DB</b> (Daughterboard Firmware version);</p> <p><b>QU</b> = VAC4S</p> <p><b>HU</b> = VAC4</p> <p><b>PIB</b> PIB Firmware version</p> <p><b>SU</b> = VAC4S</p> <p><b>OU</b> = VAC4</p> <p><b>PBL</b> PIB Bootloader Version</p>		<p><b>B</b> PBL revision</p> <p><b>NR</b> Neuron Firmware version</p> <p><b>MU</b> = VAC4S</p>
<p><b>XL</b> Xilinx Firmware version</p> <p><b>N</b> = VAC4S</p> <p>Pending Firmware status (if new firmware was available, this would list the versions)</p>		<p>License key (first and second Page 3 (scroll to third page.))</p>
<p><b>JB</b> Firmware release date</p> <p>DB revision</p>		

## 4.4 Logging Off the VAC

1. To log off a vehicle, come to a complete stop with the vehicle (and turn off the engine, if applicable) . While stopped, press the VAC's POWER button. 

**Note:** For safety reasons, the log off function is inoperable if the vehicle is in motion, or (for internal combustion vehicles) if the engine is on.



2. When an operator successfully logs off a vehicle, the vehicle will become deactivated, the VAC's main login screen will reappear, and the VAC's green LED will turn off.

**Note:** The operator is responsible for the vehicle until he/she logs off the VAC. If the operator leaves his/her vehicle without logging off, anyone could use the vehicle under the operator's name. To prevent this circumstance and avoid being held responsible for illegitimate vehicle use, an operator must log off the VAC whenever he/she leaves his/her vehicle for more than a few minutes.

The VAC will automatically time out (self-log off) after a period of non-use (The default is set to 10 minutes).



## 4.5 Answering Safety Checklists

The VAC automatically prompts operators to answer mandatory safety checklists when the following occurs:

1. Compliance with established checklist rules must be enforced, or
2. A defined event, such as an impact, has occurred.

Safety checklists can also be launched manually at any time while an operator is logged into a vehicle by pressing the CHECK button.

Current position in checklist (e.g., Question 11 of 15)

Scroll indicator vertical bar

Checklist question

Line separating question and answers. (Auto-resizes based on the number of menu options)

Selected checklist current response (highlighted)

**Quick press:** ESC key Return to the previous checklist question (exists checklist if pressed while on the first question)

**Long press:** ESC key Exits the checklist from any question



**Quick press:** Highlights menu option corresponding to key pressed.

**Long press:** Selects menu option corresponding to key pressed and advances to the next screen.

**Note:** If an operator tries to exit a checklist prior to completing all questions, the VAC screen will ask if the operator wants to exit the checklist.

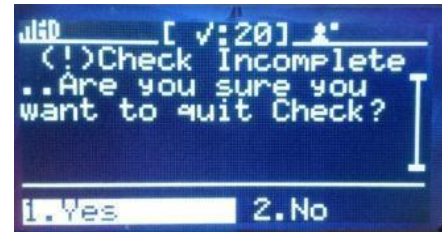

**Exiting a checklist prior to completion will violate safety compliance requirements and result in the loss of all responses to that checklist!**

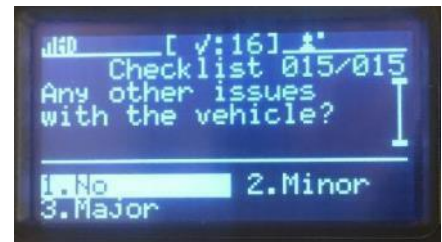

Select OK to complete the Checklist.



The completed checklist returns to the main menu display.



## 4.6 Critical Shutdown

If an operator enters a checklist response that has been defined as “critical,” prior to completing the checklist, they will be prompted to confirm that they wish to complete the checklist with at least one critical response. If the operator confirms the critical response, the checklist is completed, the operator is automatically logged off, and the vehicle is locked out.

**Note:** The vehicle will NOT lock out operators while in “Any ID” mode.

The VAC remains disabled for Standard and Master operator(s) until a Maintenance operator logs in and reactivates the vehicle.

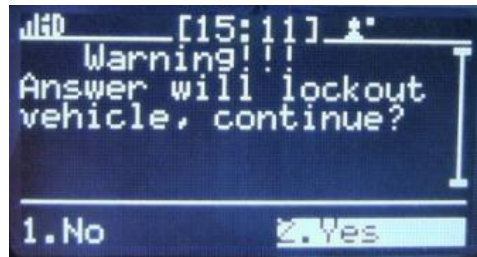

Because of this safety function, note the following:

**An operator must complete the safety checklist while the vehicle is in a safe location, away from traffic flow, in case the vehicle is deactivated.**

**Operators should only answer "Yes" to this question if they are sure the vehicle is unsafe.**

## 4.7 3.7 Operating the Vehicle

### 4.7.1 Break Mode

The VAC's "Break" option is available to all operators. This function allows an operator to reserve his/her vehicle for short periods of time (The default time is 15 minutes). To enter Break mode, from the VAC menu screen, select BREAK.

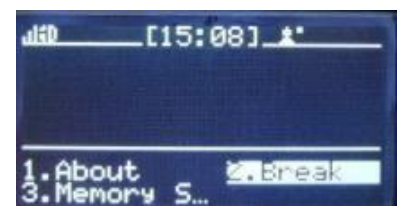

While in Break mode, the screen indicates that only the operator who put the vehicle into Break mode, a Master operator or a Maintenance operator can log into that vehicle. All other operators are prevented from logging into the VAC on that vehicle. After the break time-period, the screen changes to the standard screen and any operator will once again be able to log into the VAC on that vehicle.

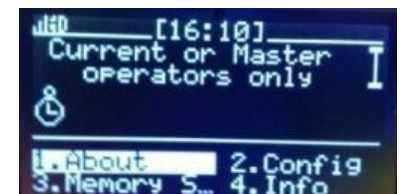

## 4.7.2 Idle Timeout

If an operator does not log off the VAC after using a vehicle, anyone could drive that vehicle under the operator's name, resulting in the loss of access control and accountability for vehicle use. To prevent this unsafe practice (and to save vehicle wear and wasted fuel), the VAC will automatically time-out after a vehicle has been idle for a period of time (the default time is 10 minutes).



When the idle timeout occurs, a countdown appears on the VAC screen and the left LED alternately blinks green and orange to alert the operator of the impending idle timeout. At the end of the countdown, the VAC logs off the operator and shuts the vehicle down. To cancel the timeout, the operator can move the vehicle or from the VAC menu screen, select SNOOZE. To use the vehicle after an idle timeout, an operator must log in again using their iButton fob/ Access ID.

## 4.7.3 Automatic Hibernate

On internal combustion vehicles, the VAC has an automatic power-down function to conserve vehicle battery power. The automatic hibernate feature puts the VAC and any peripherals into a "hibernate" mode that uses much less power than the VAC's active mode. The VAC will automatically enter hibernate mode after 35 minutes of vehicle inactivity post operator log off.



In Hibernate mode, the VAC periodically samples for activity and sends check-in records to the software. If any activity (motion, login, etc.) is sensed during the check-ins, the VAC will return to full power mode. Alternatively, you can restore the VAC to its active state ("Wake up the VAC") by pressing the VAC's POWER button (See Section 2 "Logging onto the VAC").



Another activity example is (engine, login, etc.)



## 4.7.4 Motion Safety Feature

The VAC's display and keypad are inoperable and log-off is prevented for Standard and Master operators when vehicle motion is detected. This safety feature prevents Standard and Master operators from interacting with the VAC while the vehicle is moving **Note:** Maintenance operators can always see the VAC's display and use the VAC's keypad, even if the vehicle is in motion, to enable Standard and Master operators to perform VAC configuration or troubleshooting.



## 4.7.5 Event Shutdowns (Impact, safety non-compliance, etc.)

For certain unsafe events, the VAC will state the vehicle will shut down within 30 seconds (only if the vehicle is in Registered ID mode) and a countdown will begin. “High” and “Severe” impacts, safety checklist non-compliance, and checklist critical responses all result in vehicle lockouts and require Master or Maintenance operators to ‘unlock’ the vehicle. These events are preconfigured in the VAC and Vision Pro software.



## 4.7.6 Memory Status

The VAC has onboard memory that can retain different types of data for various durations. In cases where the VAC remains outside of wireless coverage for extended periods of time, the VAC will prompt to drive to a WAM or Access Point. To check the VAC memory status at any time, from the VAC menu screen, select MEMORY STATUS. The VAC displays the memory consumed in a percentage.



The VAC Memory Status can be cleared by certain operator authorization levels. Select CLEAR MEMORY.



Clearing memory erases any performance data (vehicle usage, checklists completed, events occurred, etc.) not yet sent to the software, and forces the VAC to resynchronize before standard operators can login.

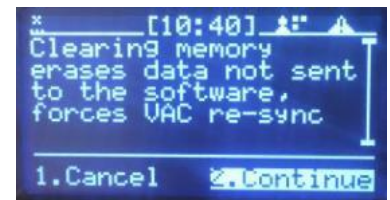

## 5 SECTION 4: MASTER OPERATORS (SUPERVISORS)

A Master operator (or a Maintenance operator) can log into any unlocked and certain locked vehicles at any time regardless of group assignments. In addition, a Master operator (or a Maintenance operator) can perform the following special functions:

### 5.1 Adding Temporary Users

A Master operator can temporarily assign a vehicle to a Standard operator who would not have access to that vehicle. For example, if a Standard operator in the “Receiving” group needs to use a “Shipping” group vehicle, a Master operator can temporarily authorize that operator on that vehicle.

The temporarily assigned operator does not have to be a valid driver in the system. If the ID is not known by the software, the ID will automatically be added as a driver (with no access privileges) to the system software.

This valuable feature ensures that the operational data is correctly assigned to the appropriate operator rather than to no one (if access control is bypassed) or to the Master operator if they let the operator use the vehicle under their ID.

**Note:** If a Master operator is assigned to groups, they can only assign temporary operators to vehicle in groups they belong to.

To temporarily authorize an operator on a vehicle, a Master or Maintenance operator must perform the following:

1 Log into the vehicle to be temporarily assigned.

2. On the first menu screen, select ACCESS.



3. On the "Access Ctrl" sub-menu, select TEMP USERS.

4. On the "Temp Users" sub-menu, select ADD USER.

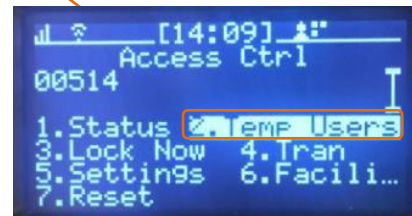

5. Touch the iButton fob, Access ID card of the Standard operator who needs to be temporarily authorized to the VAC's iButton, Access ID card reader. Then log off.

That newly assigned operator is now temporarily authorized to use that vehicle, for a period of 14 hours.

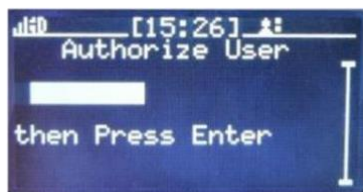
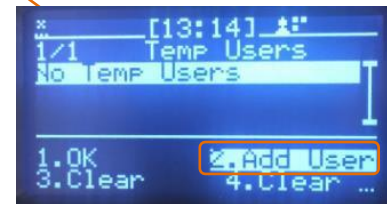

## 5.2 Clearing Event Lockouts

High and Severe impacts, failure to complete a safety checklist in the defined period (non-compliance), and checklist critical responses will shut down the vehicle and lock it out, to prevent Standard operators from using that vehicle.

**Note:** Vehicles in “Any ID” mode, are NOT subject to lockouts.

To view the cause of a lockout, log in to the locked vehicle. From the VAC menu screen, perform the following steps:

1. Select ACCESS.
2. Select STATUS.

To clear a vehicle lock-out and return the vehicle to operation, a Master operator (or a Maintenance operator) must perform the following:

1. Log into the locked vehicle.

The screen displays the following:

Lock and Operator icon is for impact and non-compliance events.

Wrench and Lock icon is for critical response events (Maintenance only)

2. Press the VAC’s CHECK button and answer the checklist questions. If the responses indicate that there are no critical safety issues, the lock-out will be cleared and the LED will turn off. If the responses indicate another critical issue, a new lockout will occur.

If there are no critical safety issues, simply log out. The vehicle will then be available to authorized Standard operators.



## 5.3 Checklist Administration

Should the need arise, the VAC provides the ability for a Master operator (or Maintenance operator) to adjust the current compliance parameters for a vehicle.

As previously described, each operator is provided (a default of) 20 minutes of login time to complete a safety checklist, when the vehicle is non-compliant. To reset the 20-minute safety checklist countdown on a vehicle,

when the operator has a next log in (perhaps in a case where maintenance inspected the vehicle ad hoc), perform the following:

1. Log into the vehicle.
2. On the first menu screen, select CHECKLIST.



3. On the "Checklist Admin" sub-menu, select RESET.

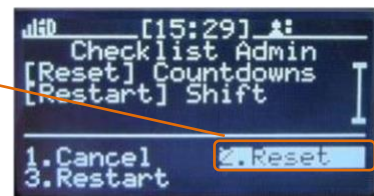

To force operators to complete the VAC safety checklist at the next login, perform the following: (For example, where a Maintenance operator worked on a vehicle, and now you want operators to validate the changes through a safety inspection).

1. Log into the vehicle.
2. On the first menu screen, select CHECKLIST.
3. On the "Checklist Admin" sub-menu, select the RESET menu option.

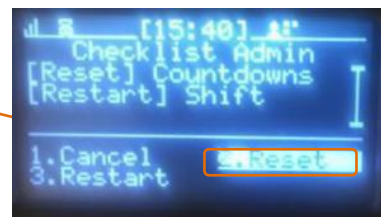
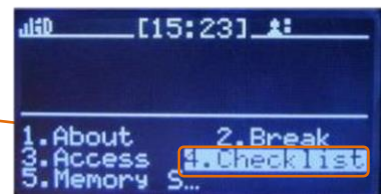

## 5.4 Manual Vehicle Lock

In certain instances, (e.g., when a vehicle requires maintenance) it may be desirable to prevent all Standard operators from accessing a vehicle (typically called a lockout or tag-out).

When a vehicle is locked, only a Master operator (or a Maintenance operator) can access and use that vehicle.

To lock a vehicle, a Master (or Maintenance) operator must perform the following:

1. Log into the vehicle.
2. On the first menu screen, select ACCESS.
3. On the "Access Ctrl" sub-menu, select LOCK NOW.



## 5.5 Manual Vehicle Unlock

To unlock a vehicle, a Master (or Maintenance) operator must perform the following:

1. Log into the vehicle.
2. On the first menu screen, select ACCESS.
3. On the "Access Ctrl" sub-menu, select UNLOCK.

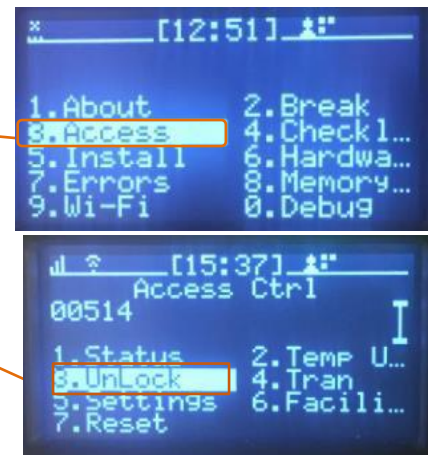

## 6 SECTION 5: MAINTENANCE OPERATORS

Maintenance operator can perform the same special functions as a Master operator.

See “Temporary Users,” “Clearing Event Lockout,” “Checklist Administration,” and “Manual Vehicle Lock/ Unlock” under Section 4: Master Operators (Supervisors).

A Maintenance operator can also perform the following additional special functions:

### 6.1 Installation and Configuration

Maintenance operators are required to install and configure the VAC before the VMS system can operate. Installation and configuration must take place when the VAC is powered up for the first time, and when a VAC is replaced.

Maintenance operators should not enter the Install menu unless they need to re-configure the VAC. See Section 2: Configuring the VAC, for more details on VAC configuration.



#### VAC Timer Reset After Completed PM

Preventative Maintenance (PM) due dates are established automatically through the Powerfleet® Vision Pro™ software, based on vehicle activity hours tracked by the VAC.

When a PM is complete, the VAC’s activity timer must be reset, so the next PM due date can be automatically determined.

To reset the VAC timer, a Maintenance operator must perform the following:

1. Log into the vehicle.

2. Press the VAC's CHECK button.

3. Select YES, to the checklist question about PM performance.

**Note:** If the Maintenance operator selects the NO response, the system will continue to accrue data with "PM Date" and "Hours Since Last PM" based on the last time the VAC timer was reset.



## Diagnostic Errors

The VAC has built-in intelligence to diagnose and report errors. In certain cases, these errors auto correct themselves; in other cases, the errors must be resolved and then 'cleared'.

These diagnostic errors are based on operating parameters that may indicate the VAC is not operating properly.

When an error is active, the RED LED blinks and the screen displays a blinking error icon.

See Section 7: VAC Troubleshooting, for details on the error definitions and troubleshooting steps.

Some errors clear themselves after the issue has been corrected (e.g., "Memory full").

For other errors, Maintenance operators can clear the reported error on the VAC once the issue has been resolved.

To clear an error report, perform the following:

1. Log into the vehicle.

2. On the first menu screen, select ERRORS.



3. On the "ERRORS" sub-menu, select CLEAR.

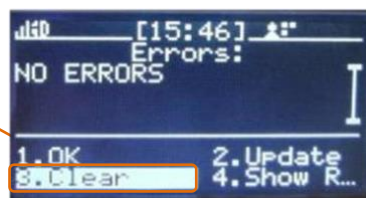

4. Select OK to exit the screen.

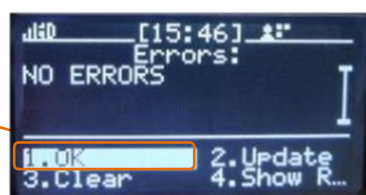

## 6.2 ID Optional ('Soft' Bypass)

A Maintenance operator can bypass the access control feature of the VAC via firmware, **allowing anyone to operate a vehicle**. This is called ID Optional mode ("soft bypass").

It is most typically used if there is a VAC problem that prevents authorized operators from accessing a vehicle.

**Note:** The soft bypass option should only be used in emergencies!

To enable or disable the ID Optional mode, a Maintenance operator must perform the following:

1. Log into the vehicle.

2. On the first menu screen, select ACCESS.



3. On the "Access Ctrl" sub-menu, select SETTINGS.

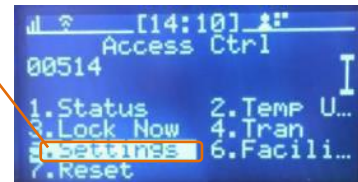

4. On the "Settings" sub-menu, one of the following three menu options:

- Selecting ID OPTIONAL will put the vehicle into soft bypass - operators will NOT be required to log in to use the vehicle (though operators may log in if they choose).
- Selecting REGISTERED IDs disables soft bypass, restoring vehicle access control - operators will again be **required** to log in to use the vehicle.
- Selecting ANY ID requires operators to log in with any hardware-compatible ID (Any ID ignores software configuration). However, the VAC will not act (i.e., lockouts, email, etc.) on events.

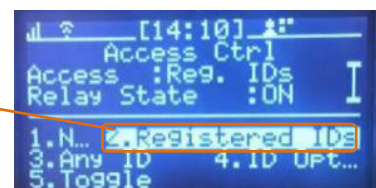

**Note:** The software setting for Any ID or Registered ID mode overrides the VAC-based selection if the VAC is in wireless coverage range.

- The TOGGLE option is for troubleshooting the VAC's access control relay. Toggle does not affect the access method, but it does alternately enable and disable the truck's drivability state by toggling the output (relay or PWM).



## 6.4 Replacing an Existing VAC

When a VAC needs to be replaced, a Maintenance operator can automatically configure the new VAC with the previous VAC's settings, using the "CloneVAC" menu option. This eliminates the need to re-run the Install Wizard by wirelessly transferring all settings and meters from the previous VAC to the replacement VAC, based on the last reported data for the specified VAC ID number. **IMPORTANT:** When replacing an existing VAC, **DO NOT** use the VAC's Install Wizard!

After connecting a replacement VAC to an existing VAC cable, the VAC screen will display an error message when it powers up. Ignore this error.

After connecting a replacement VAC to an existing VAC cable, the VAC screen will display an error message when it powers up. Ignore this error.

1. Log into the vehicle.
2. Park the vehicle safely near a WAM or at a location with a strong Wi-Fi signal.
3. For Wi-Fi systems, enter valid Wi-Fi credentials and facility ID and verify the VAC connects.
4. Select INSTALL. Navigate to the "Choose Installation Type" screen.



5. Select NEXT.

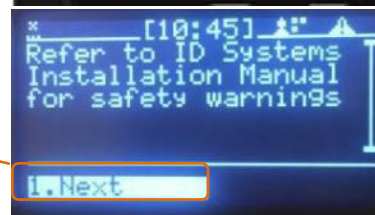

6. Select NEXT.

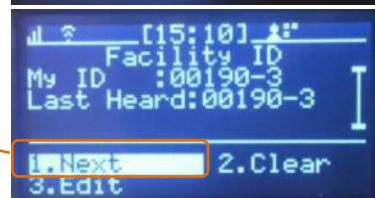

7. Select CLONE VAC.

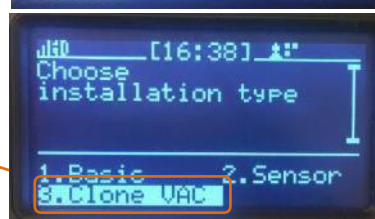

8. Enter the vehicle ID to clone the VAC.



9. When prompted, enter the facility ID, vehicle type and vehicle ID number. Be sure to enter all leading zeros in the ID number.

The VAC will automatically download the configuration data associated with that vehicle ID and display one of the following messages:

VAC Message	Meaning
<b>Configured Success</b>	The replacement VAC is successfully configured.
<b>Not All Configured</b>	Some configuration data is missing or different than the previous VAC (This is likely to occur if the replacement VAC has a newer firmware version than the VAC being replaced). In this case, a Maintenance operator must manually configure the replacement VAC as if it was a new vehicle installation, using the VAC's Install Wizard. Refer to Powerfleet Installation Guide.
<b>Wrong Version!</b>	The previous VAC had a significantly older version of firmware than the replacement VAC. In this case, contact the local System Administrator or Powerfleet support team.
<b>VAC NOT FOUND</b>	The VAC ID is not found in the system database. In this case, the vehicle ID should be double-checked with the local System Administrator, and the "CloneVAC" process re-run. Then the correct vehicle type and vehicle ID can be entered.

**Note:** If a VAC is moved from one vehicle to another vehicle, use the VAC's Install Wizard, not the "CloneVAC" function. (See Section 2: Configuring the VAC).

## 6.5 Checking VAC Synchronization Status

For communication efficiency purposes, there are many VAC profile segments that can be updated and synchronized independently. The Vision Pro software displays the synchronization status for all communicating vehicles. However, the following explains the content. On the VAC menu screen:

1. Select ACCESS.
2. Select TRAN, to check on a particular VAC's synchronization status.  
Incremental count when in range  
(always increments in range)

**Note:** If the "M" number is less than the "C" number, then the VAC's segment is not updated.

Profile segment name

**P** Pending version

**M** Latest version required

**Rec** Records received for synchronizing segments



**C** Date and Time of last completed update

**U** Latest version on the VAC

**M** Version retained following a firmware upgrade

Profile Segment		Description	
Empl	E	Employees	This segment increments when any employees and groups are added, deleted, or updated in Powerfleet Vision Pro software.
Elst	L	Employee bit list	This segment increments with any change in the "Empl" segment or when an employee group assignment is updated in Vision Pro software.
Auth	A	Authorization schedule	This segment increments when a group authorization schedule (day of week, hour of day, etc.) is added, deleted, or updated in Vision Pro software.
Quest	Q	Checklist questions	This segment increments when checklist questions or answers are added, deleted, or updated in Vision Pro software.
Behaviors	H	Vehicle checklist profiles	This segment increments when hierarchical profiles (triggers, criteria, question sets, etc.) are added, deleted, or updated in Vision Pro software.
Prof	P	Profile	This segment increments when any of the vehicle's sensor configuration (idle, sleeper, power-down, GPS, etc.) is edited in Vision Pro software or when vehicles are added or deleted.
SysP	S	System Profile	This segment increments when system level parameters (frequency, facility code, system-wide sensor configuration, etc.) are updated added, deleted or updated in Vision Pro software.
SyP2	Y	System Profile 2	This segment increments when Wi-Fi, diagnostic or shift parameters are updated added, deleted or updated in Vision Pro software.
GeoF	F	Geo-Fence	This segment updates when zones (Violation, Blockout, etc.) or the facility map are changed in the Maps module of Vision Pro software.

## 6.6 Reset VAC Synchronization

In certain troubleshooting scenarios, the VAC's downloaded profile (operators, groups, checklists, etc.) may need to be reset in order to force a re-synchronization. The reset Authorization function can only be performed with an access code provided by Powerfleet Support. Select RESET.



Enter access code.

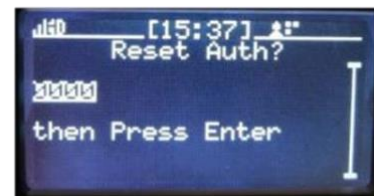

## 6.7 Changing the VAC Facility ID

The facility ID entered in the VAC is the unique identifier that allows the VAC to communicate with the correct Powerfleet Vision Pro software database. The facility code is first entered during the VAC configuration process but can be updated at any time. From the VAC menu screen, perform the following steps:

1. Select ACCESS.
2. Select FACILITY ID. You can obtain your facility ID from Powerfleet's Support. Alternatively, if you are using WAMs or a customer-hosted Wi-Fi system perform the following:
3. Select CLEAR or enter zero in the facility ID field.

The VAC will communicate with, and display the Facility ID of, the first system within wireless communication range.

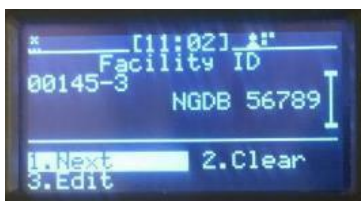

**Note:** When the VAC is within wireless communication range of a facility ID different than the one entered during configuration, diagnostic error #25 will appear on the VAC display screen.

## 6.8 Forcing the VAC to Low Power Mode (Hibernate)

The VAC's power consumption is extremely low. However, when installed on internal combustion vehicles, it is programmed to automatically enter a low-power mode otherwise known as 'hibernate' after a period of non-use. If you need to force the VAC to hibernate mode (e.g., vehicle is in maintenance for a long period of time), from the VAC menu screen, select HARDWARE, and then select HIBERNATE menu option.

**Note:** In Hibernate mode, the VAC will occasionally automatically wake up and check for activity to determine if it should return to full power mode.

1. Log into the vehicle.
2. From the VAC menu screen, select HARDWARE.
3. On the "HARDWARE" sub-menu, select HIBERNATE. As soon as Hibernate is selected, the VAC will change to low power mode and log the operator out.

## 6.9 Checking VAC Internal Backup Battery (not applicable for all VAC types)

A VAC's internal backup battery preserves configuration settings and recent activity data when a VAC loses power (e.g., during vehicle battery charge/ swap).

If this backup battery discharges completely, the VAC will lose some of its settings, including access control authorizations.

The VAC must be fully synchronized with the system database to resume normal operation. There is a diagnostic error code that displays when the backup battery has a low charge.

However, if you want to proactively check a battery to ensure it is charging, a Maintenance operator must perform the following:

1. Log into the vehicle.
2. Select HARDWARE.
3. Scroll down to the second page of the menu screen.
4. On the "Hardware" sub-menu, select BACKUP BATTERY.



The VAC screen provides the battery condition of Charged, Charging or Not charging:

<b>Charged</b>	Battery is fully charged.
<b>Charging</b>	Battery is not fully charged, but it is charging correctly and should be <u>fully charged within 30 minutes.</u>
<b>Not charging</b>	Battery is not charging correctly. Contact Powerfleet's Support team.



## 6.10 Changing the VAC Data Transmission Settings

Maintenance operator must perform the following:

1. Log into the vehicle.
2. Select HARDWARE.

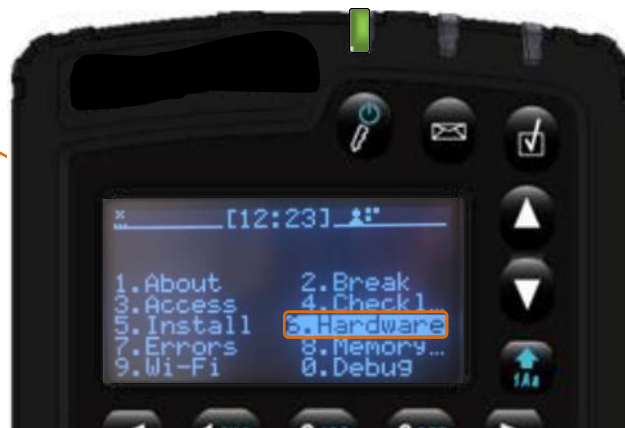

3. On the "Hardware" sub-menu, select ID+RF.

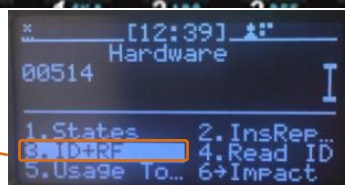

4. On the "ID+RF" sub-menu, to change the RF communication frequency, select MyFreq.

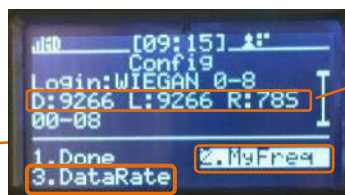

- D** Data Frequency, iRF VAC data transmission
- L** Location Frequency, iRF uses to determine VAC location
- R** Data Rate, iRF data speed setting

Maintenance operator must perform the following:

1. Change VAC location frequency by selecting SET LOC and picking the desired frequency



Change VAC data frequency by selecting SET DATA and picking the desired frequency.

2. On the "ID+RF" sub-menu, select DataRate to change the VAC transmission data rate.



## 6.11 Checking and Changing the VAC Usage Totals

Maintenance operator must perform the following:

1. Log into the vehicle.
2. Select HARDWARE.



3. On the "Hardware" sub-menu, select Usage Totals.





## 6.12 Testing the BLU wire connection prior to VAC Configuration

(Not applicable for JPT, P-Plug and VDI cable installations)

Per the installation instructions, installers need to measure voltage changes for connection points of the inputs required.

The “BLU” wire is used for motion sense (drive motor on electric vehicles and in gear on internal combustion vehicles). There are 2 modes for motion configuration, “V(avg)” and “V(mix/max)”.

**V(avg)** uses the average voltage reading, typically used for DC voltage and AC square wave voltage signals.

**V(min/max)** uses the peak-to-peak voltage reading, typically used for AC sine wave voltage signals.

To be sure the BLU wire connection will work for the Install Wizard, there is a MotionTest screen available to see the VAC results in either of these modes.

Connect the BLU wire using clip-leads, or permanently and then:

1. Log into the vehicle.
2. On the first menu screen, select HARDWARE.
3. On the "Hardware" sub-menu, select MOTIONTEST.



**R** "Raw" value currently being measured by sensor



**AV** Current Value evaluated versus idle ranges to determine vehicle state.

Use the up and down arrows  
To switch between modes

4. Select the desired mode.
5. Note the idle (not driving) value of AV with the key off.
6. Note the idle (not driving) value of AV with the key on.
7. Drive and note the value of AV (needs to be more than 10 points different than the non-driving values).
8. If not, switch modes and repeat steps 5 through 7.
9. If neither mode provides the desired results, you need to find a different connection point.

## 6.13 Understand and Manually Set "Motion" for Electric Vehicles

(Not applicable for JPT, P-Plug and VDI cable installations)

The VAC installation and configuration wizard is always used for establishing motion and idle thresholds on a vehicle. In some cases, motion and idle values may need to be adjusted during troubleshooting. One reason may be that the vehicle will not pass the initial configuration wizard. Another reason may be that motion diagnostic errors appear regularly.

The VAC determines the state of the vehicle (idle or motion) by configuring two 'idle' ranges based on voltage sampling of the "BLU" wire connection. The sampling methods (the numbers displayed) are different depending on the Vehicle Type (e.g. Elec avg, Elec min/max). The two idle ranges will typically differ when the "BLU" connection voltage changes between key-on and key-off while the motor is disengaged. In other scenarios, the two idle ranges may be identical.

1. Log into the vehicle.
2. On the first menu screen, select HARDWARE.



3. Scroll down to the second page of the menu screen.
4. On the "Hardware" sub-menu, select MOTION.

**Idle or Motion** Current 'motion' state of the vehicle. **MUST BE VALIDATED VIA TEST DRIVE AFTER CHANGING SETTINGS**

**R** "Raw" value currently being measured by sensor

**Id1** Center point for first 'idle' setting range.

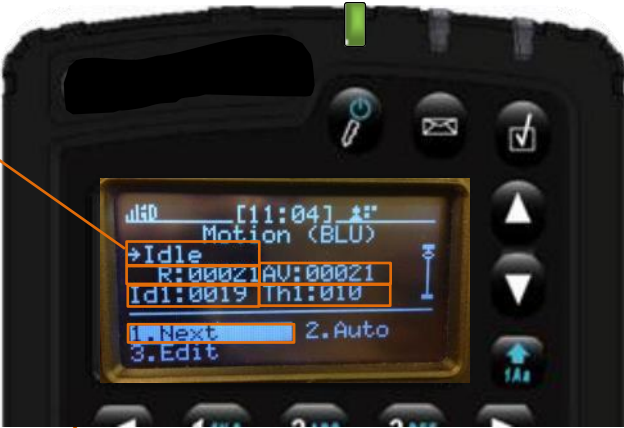
**Id2** Center point for second 'idle' setting range.

**AV** Current value evaluated versus idle ranges to determine vehicle state.

**Th1** The threshold above and below Id1 center point that equals the 'idle' range.

**Th2** Threshold above and below Id1 center point that equals the 'idle' range.

Select EDIT which opens a new screen where you can type in the required values between 0 and 1023 (center point) and between 0 and 255 (range). This method is a last resort and would be used in a trial-and-error scenario with assistance from Powerfleet Support.

- IDLE1** Center point for 1st idle setting.
- THR1** Range around (+/-) the "IDLE1" setting that makes the idle threshold.
- IDLE2** Center point for 2nd idle setting.
- THR2** Range around (+/-) the "IDLE2" setting that makes the idle threshold.
- Pictured example** Vehicle is idle when AV is between 0 and 510 ( $255 \pm 255$ ) or 510 and 1020 ( $765 \pm 255$ ).



## 6.14 Understand and Manually Set "Idling" for Internal Combustion Vehicles

(Not applicable for JPT, P-Plug and VDI cable installations)

The VAC determines the state of the vehicle (engine off, idling or motion) by configuring two 'engine off' ranges based on voltage sampling of the "BRN" wire connection. The two Engine-off ranges will typically differ when the "BRN" connection voltage changes between key-on accessories and key-off while the engine is not running. In other scenarios the two idle ranges may be identical.

1. Log into the vehicle.
2. On the first menu screen, select HARDWARE.
3. Scroll down to the second page of the menu screen.
4. On the "Hardware" sub-menu, select ENGINE.

**IG** Current gear state  
(N=Neutral,  
G = In gear)

**MUST BE VALIDATED VIA  
TEST DRIVE AFTER  
CHANGING SETTINGS**

**Idle or  
EngOn** Current engine state ('Idle'  
= Engine off, 'EngOn' =  
Idling)

**R** "Raw" value currently  
being measured by sensor

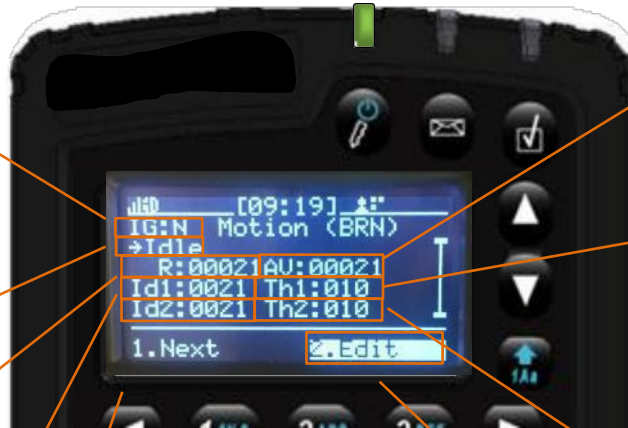

**AV** Current  
value  
evaluated  
versus engine  
off ranges to  
determine  
engine state

**Th1** Threshold  
above and  
below Id1  
center point  
that equals  
the 'engine  
off'  
range

**Th2** Threshold  
above and  
below Id1  
center point  
that equals  
the 'engine  
off'  
range  
Type in  
Samples to  
Edit

**Id1** Center point for first  
'engine off' setting  
range

**Id2:** Center point for second 'engine off' setting range.



Select EDIT which opens a new screen where you can type in the required values between 0 and 1023 (center point) and between 0 and 255 (range). This method is a last resort and would be used in a trial-and-error scenario with assistance from Powerfleet Support.

- IDLE1** Center point for 1<sup>st</sup> neutral setting.  
Range around (+/-) the "IDLE1" setting that makes the engine off
- THR1** threshold.
- IDLE2** Center point for 2nd engine off setting.  
Range around (+/-) the "IDLE2" setting that makes the engine off
- THR2** threshold.

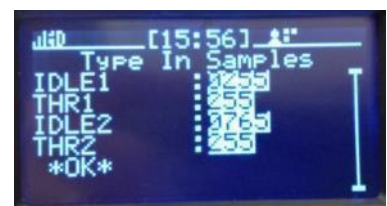

**Pictured example**

Vehicle engine is off when AV is between 0 and 510 (255 ± 255) or 510 and 1020 (765 ± 255).

## 6.15 Understand and Manually Set "Motion" for Internal Combustion Vehicles

(Not applicable for JPT, P-Plug and VDI cable installations)

The VAC determines the state of the vehicle (idling or motion) by configuring two 'in neutral gear' ranges based on voltage sampling of the "BLU" wire connection while the engine is on (as determined by the "BRN" wire connection). The two neutral gear ranges may differ in some scenarios.

1. Log into the vehicle.
2. On the first menu screen, select the HARDWARE menu option.
3. Scroll down to the second page of the menu screen.
4. On the "Hardware" sub-menu, select GEAR.

**Neutral or In Gear** Current 'motion' state ('Neutral' = idling, 'In Gear' = motion)

**MUST BE VALIDATED VIA TEST DRIVE AFTER CHANGING SETTINGS**

**R** "Raw" value currently being measured by sensor.

**Id1** Center point for first 'idling' setting range.

**Id2** Center point for second 'idling' setting range.

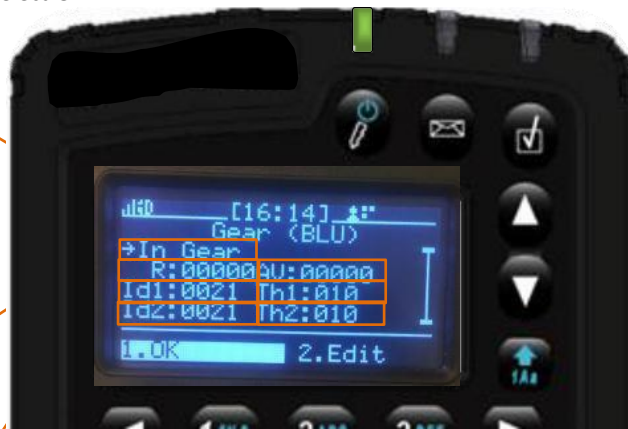

**AV** Current value evaluated versus idling ranges to determine vehicle state.

**Th1** The threshold above and below Id1 center point that equals the 'idling' range.

**Th2** The threshold above and below Id2 center point that equals the 'idling' range. Type in Samples to Edit

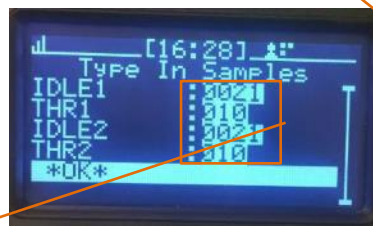

Select EDIT which opens a new screen where you can type in the required values between 0 and 1023 (center point) and between 0 and 255 (range). This method is a last resort and would be used in a trial-and-error scenario with assistance from Powerfleet Support.

- IDLE1** Center point for 1st neutral setting.
- THR1** Range around (+/-) the "IDLE1" setting that makes the neutral threshold.
- IDLE2** Center point for 2nd neutral setting.
- THR2** Range around (+/-) the "IDLE2" setting that makes the neutral threshold.

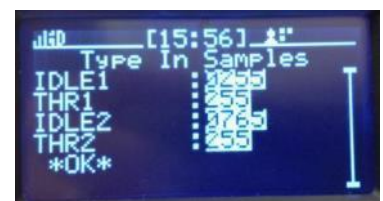

**Pictured example** Vehicle is idling when AV is between 0 and 510 (255 ± 255) or 510 and 1020 (765 ± 255)

## 6.16 Current VAC Configuration (“States” Screen)

The VAC has up to 3 read-only status screens of current VAC configuration settings.

The screen content is dependent on the VAC license key. Therefore, every VAC may not contain all of the following:

1. Log into the vehicle.
2. On the first menu screen, select HARDWARE.
3. On the “Hardware” sub-menu, select STATES.
4. Values auto-update to the most current reading
5. Select PAUSE to freeze all entries to last read values.

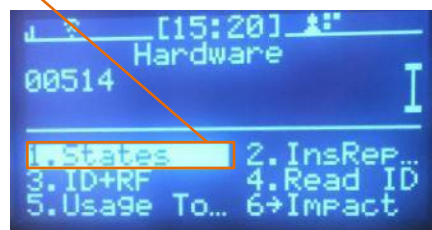

Electric vehicle and IC vehicle

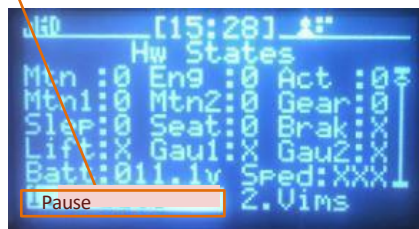

6. The VIMS options display the current connection setting for each configurable parameter.
7. Select VIMS again and the VAC will display the enabled options only. Pick any of the enabled options to see the detailed configuration interface.

The activity definition is on the following page.

Item	Description	Values
<b>Mtn</b>	Motion meter; same as Mtn1 or a combination of Mtn1 and Mtn2.	0, 1, or X
<b>Eng</b>	Engine-on meter; used for internal combustion vehicles only (BRN wire)	0, 1, or X
<b>Act</b>	Activity meter as assigned during the VAC install Sensor wizard.	0, 1, or X
<b>Mtn1</b>	Motion meter; BLU wire (electric), Eng+Gear (internal combustion)	0, 1, or X
<b>Mtn2</b>	Not currently available	X

<b>Gear</b>	In gear; used for internal combustion vehicles only (BLU wire)	0, 1, or X
<b>Slep</b>	Sleeper mode; <b>Seat</b> = 1 but <b>Mtn, Mtn1, Mtn2, Sped, Act,</b> and <b>Lift</b> = 0 or X	0, 1, or X
<b>Seat</b>	Seat or dead-man meter (PUR wire)	0, 1, or X
<b>Brak</b>	Parking brake interface; prevents operator logoff unless brake is applied	0, 1, or X
<b>Lift</b>	Lift motor meter	0, 1, or X
<b>Gau1</b>	Vehicle gauge (or indicator); typically, high engine temperature	0, 1, or X
<b>Gau2</b>	Vehicle gauge (or indicator); typically, low oil pressure	0, 1, or X
<b>Batt</b>	Vehicle battery voltage	000.0V
<b>Sped</b>	Current vehicle speed (based on odometer or GPS)	0 – 99.9 mph
<b>LftW</b>	Load meter (motion with load, travel with load, etc.)	0, 1, or X
<b>DlyT</b>	Tow meter	0, 1, or X
<b>Batt</b>	Current vehicle battery voltage (B+ wire)	0 – 99.9 volts
<b>Im X, Y, P</b>	Current impact sensor X-axis, Y-axis, and duration thresholds	0 – 255
<b>Creep</b>	CAN/Serial mode that activates unsafe mode	0, 1, or X
<b>Speed</b>	When unsafe mode is active, shows if drive speed is limited in unsafe mode	0, 1, or X
<b>Lift1</b>	When unsafe mode is active, shows if lift speed is limited in unsafe mode	0, 1, or X
<b>TEMP</b>	Last recorded, Average recorded readings for VAC internal temperature (in C)	C
<b>BLU</b>	Active/Inactive - Last recorded - Avg values for Mtn1 (electric), Gear (IC)	0-00000-00000
<b>PUR</b>	Active/Inactive - Last recorded - Average recorded values for Seat	0-00000-00000
<b>BRN</b>	Active/Inactive - Last recorded - Avg values for Mtn1 (electric), Eng (IC)	0-00000-00000
<b>RED</b>	Active/Inactive - Last recorded - Avg recorded values for Batt	0-00000-00000
<b>TMP</b>	Active/Inactive - Last recorded - Avg recorded values for internal VAC temperature (in C x 10; 315 = 31.5)	0-00000-00000
<b>VBN</b>	Active/Inactive - Last recorded - Avg recorded values for Mtn2 (electric, IC)	0-00000-00000
<b>Activity</b>	Determines activity, if wake is enabled and calculates activity wake modules	00000-00-00

**0 = currently inactive, 1 = currently active, X = feature disabled**

**Note:** See the following table for most common Activity assignments. Additional combinations are possible, contact Powerfleet’s Support if the value displayed is not shown).

ACTIVITY ASSIGNMENT	NONE	MOTION	ENGINE	GEAR	LIFT	SEAT	LOAD	TOW	MOTION 2
00000	X								
00001			X						
00002				X					
00003			X	X					
00004		X							

00008									X
00009			X						X
00010					X				
00012				X	X				
00014		X			X				
00018					X				X
00082				X		X			
00084		X				X			
00092				X	X	X			
00094		X			X	X			
02002				X			X		
02004		X					X		
04002				X				X	
04004		X						X	
0000A				X					X
0000B			X	X					X
0000C		X							X
0001A				X	X				X
0001C		X			X				X
0008A				X		X			X
0008C		X				X			X
0009A				X	X	X			X
0009C		X			X	X			X
0200A				X			X		X
0200C		X					X		X
0400A				X				X	X
0400C		X						X	X

The current assignment status of each sensor displayed. From the VAC menu screen, perform the following steps:

1. Select HARDWARE.
2. Select STATES.
3. Select Vims.



If “No Hub” accompanies the VIM assignment, then the VAC is not currently sensing a valid Sensor Hub. Refer to the Vehicle Installation Guide for more details on VIM assignments.

## 6.17 Last VAC Configuration (“InsReport” Screen)

Every time the BASIC or SENSOR wizard is completed, from the VAC menu screen, select HARDWARE. Select InsReport. The InsReport on the VAC screen display provides the detail of the last completed configuration parameter.

1. Select HARDWARE

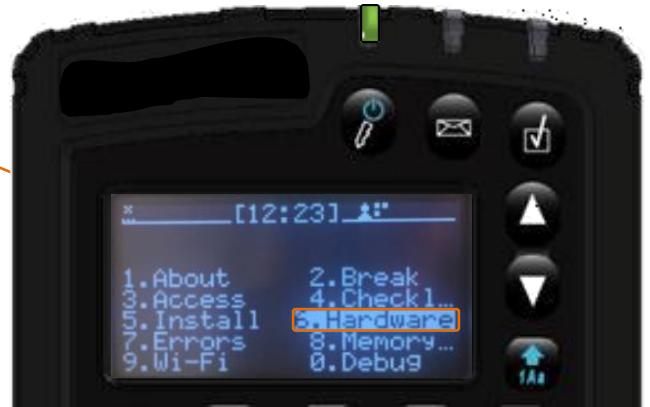

IC vehicle

Electric vehicle

1. Select InsReport.

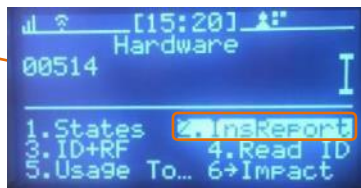

**VacID:** Vac Identification number.

Scroll down to the second page of the menu screen.

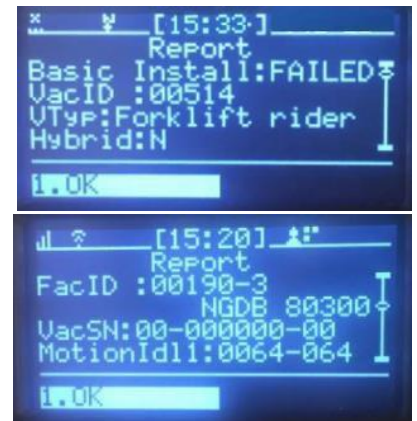
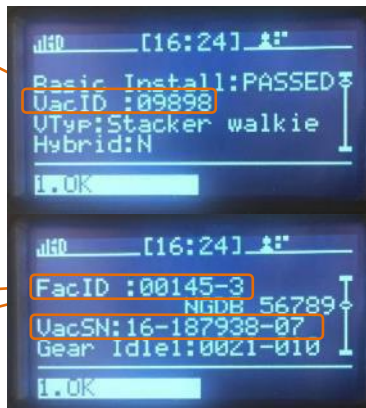

**FacID:** Facility ID lists the facility number.

**VacSN:** VAC Serial number.

Select OK to return to the main menu.

Select "Transmit" to send the configuration parameters to the software.

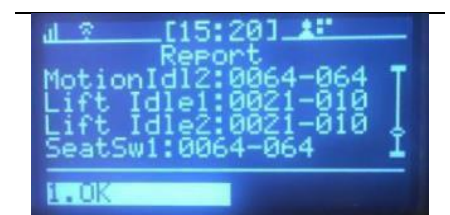
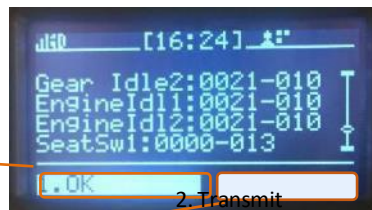

Select OK to return to the main menu.

Select "Transmit" to send the configuration parameters to the software.

The items and description are as follows:

Item	Description	Values
Basic Install	Status of the BASIC configuration wizard	Passed, Failed
VacID	Vehicle ID entered during the BASIC wizard	1 - 65534

<b>VTyp</b>	Vehicle type selected during the BASIC wizard	Varies
<b>Hybrid</b>	The VAC is configured for wired and OEM plug inputs (Y) or wired or OEM plug (N)	Y or N
<b>FacID</b>	Facility ID entered as well as facility code name (if sync'd with software)	Varies
<b>VacSN</b>	VAC serial number (excluding manufacturing site and product type)	Varies
<b>MotionId1</b>	Motion (BLU wire; electric vehicles) "inactive" 1st set point and range	SSSS-RRR
<b>MotionId2</b>	Motion (BLU wire; electric vehicles) "inactive" 2nd set point and range	SSSS-RRR
<b>EngineId1</b>	Engine On (BRN wire; GAS/IC vehicles) "inactive" 1st set point and range	SSSS-RRR
<b>EngineId2</b>	Engine On (BRN wire; GAS/IC vehicles) "inactive" 2nd set point and range	SSSS-RRR
<b>GearIdle</b>	Motion (BLU wire; GAS/IC vehicles) "inactive" 1st set point and range	SSSS-RRR
<b>GearIdle2</b>	Motion (BLU wire; GAS/IC vehicles) "inactive" 2nd set point and range	SSSS-RRR
<b>Lift Idle1</b>	Lift motor (BRN wire; electric vehicles) "inactive" 1st set point and range	SSSS-RRR
<b>Lift Idle2</b>	Lift motor (BRN wire; electric vehicles) "inactive" 2nd set point and range	SSSS-RRR
<b>SeatSw1</b>	Seat or deadman switch (PUR wire) "inactive" 1st set point and range	SSSS-RRR
<b>SeatSw2</b>	Seat or deadman switch (PUR wire) "inactive" 2nd set point and range	SSSS-RRR
<b>Gauge1Id1</b>	Gauge 1 (VIM10) "inactive" 1st set point and range	SSSS-RRR
<b>Gauge1Id2</b>	Gauge 1 (VIM10) "inactive" 2nd set point and range	SSSS-RRR
<b>Gauge2Id1</b>	Gauge 2 (VIM11) "inactive" 1st set point and range	SSSS-RRR
<b>Gauge2Id2</b>	Gauge 2 (VIM11) "inactive" 2nd set point and range	SSSS-RRR
<b>WarnAreaId1</b>	Warn Area (VIM10) "inactive" 1st set point and range	SSSS-RRR
<b>WarnAreaId2</b>	Warn Area (VIM10) "inactive" 2nd set point and range	SSSS-RRR
<b>AlertAreaId1</b>	Alert Area (VIM11) "inactive" 1st set point and range	SSSS-RRR
<b>AlertAreaId2</b>	Alert Area (VIM11) "inactive" 2nd set point and range	SSSS-RRR
<b>BatSwap</b>	Battery change confirmation configuration	Enabled, Disabled
<b>ExtIndictr</b>	Output Alert (VIM7) "inactive" set point and range	Passed, Failed
<b>BrakIdle</b>	Parking Brake (VIM8) "inactive" set point and range	SSSS-RRR
<b>ForkLoad</b>	Fork load sensor configuration	Configured, Not Configured
<b>Tow Thrsh</b>	Tow sensor (VIM5) "inactive" set point and range	SSSS-RRR
<b>Relay</b>	State of access control relay	Enabled, Bypassed
<b>Bytes</b>	Information IDSY Support may request to troubleshoot install issues	Varies
<b>GPS</b>	GPS sensor (C102 or VIM1) configuration	Varies
<b>Impact</b>	Impact sensor configuration	Varies

**SSSS = set point value, RRR = range value, Y = yes, N = no**

## 6.18 Impact Sensor Troubleshooting

Once the impact sensor has been properly installed, it is self-contained and self-maintained, and no operator configuration is required. During the installation process, the impact sensor self-calibrates to its environment

(like setting the 'zero' level of a scale). This is NOT the process that determines the minimum impact level. The impact level is continuously evaluated and adjusted. The calibration is repeated daily during periods of inactivity to ensure that the device is maintaining acceptable impact parameters and identifying possible issues (e.g., the mounting becomes compromised and results in a "floating" sensor). If issues are identified, manual troubleshooting may be required.

**Note:** A properly mounted and secured impact sensor is the most important factor in ensuring a working impact management system.

**Reading the Impact Screen:**

1. Log into the vehicle.
2. On the first menu screen, select HARDWARE.
3. On the "Hardware" sub-menu, select IMPACT.

**CR** Current sensor reading (refreshes automatically) for X and Y axis

**P** The Period a reading takes in milliseconds.

**POS** Current initial force (g) threshold for creating an impact event.

**NEG** Current initial force (g) threshold for creating an impact event.

**X and Y** Should both be  $0.0g \pm 0.2g$  when the vehicle is parked in a flat location. (Also, normal values should be between 70 and 90 when flat).



**Note:** There are 4 additional impact VAC screen displays with detailed readings and settings that can be accessed by scrolling down. Powerfleet Support may request information about the detailed readings and settings from those screens for remote troubleshooting.

## 6.19 Manually Enabling Impact Calibration

If impact errors are reported and the impact sensor needs to be remounted and/or recalibrated to resolve the issue, the recalibration process may be manually enabled; (As opposed to waiting for the automatic daily self-calibration to occur, to ensure the issue has been fixed).

1. Log into the vehicle.
2. On the first menu screen, select HARDWARE.
3. On the "Hardware" sub-menu, select IMPACT.
4. On the "Impact" sub-menu, select RECALIBRATE.

**Note:** The recalibration process is instantaneous and may be repeated as many times as needed.

The "CR:" X and Y reading should change to  $\pm 00.0g$  or  $\pm 00.1g$  to indicate a valid calibration.

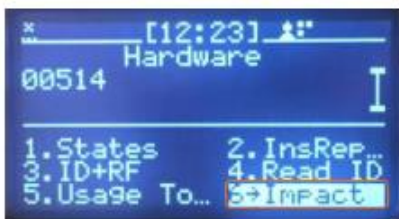

**Note:** Selecting UPDATE will update the current reading display without recalibration.

5. Select OK when the calibration is acceptable.

**Note:** The Toggle Log option enables and disables (default) detailed impact sensor reading logs which will rapidly consume the VAC memory. The Toggle Log option should only be selected at the request of Powerfleet Support.

## 6.20 Check Vehicle Battery Voltage Monitoring

The vehicle battery charge state is monitored in terms of voltage using the vehicle cable's RED (B+) wire. The status of the monitoring can be checked at any time. From the VAC menu screen: Select HARDWARE. From the second menu screen, Select V-In.

**CRA** Current Reading  
ADC

**AV** Average measure

**CAV** Current average  
measure

**Err** Error count over all  
readings



**CRV** Current voltage  
reading

**Th** Low battery  
warning  
threshold

**Log** 0 = Not enabled  
1 = Enabled

**R1** Threshold

## 7 SECTION 7: VAC TROUBLESHOOTING

### 7.1 Recommended maintenance tool list

Socket sets (metric, fractional inch)	Wire stripper/ cutter
Combination wrenches (metric, fractional inch)	Utility knife
Screwdrivers	Multimeter
Allen Wrenches	Flashlight
Pliers (channel lock, needle nose)	Electrical tape

## 7.2 VAC to Wired Vehicle Cable Pinout and Fuses

Cable  
PINS

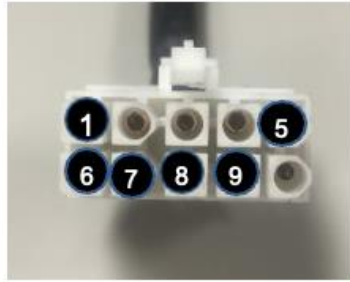

1 "B+" (red)				5 "1" (yellow)
6 "BLU" (blue)	7 "BRN" (brown)	8 "PUR" (purple)	9 "B-" (black) -AND- "0" (green)	

Fuses

Open the fuse holders by placing a flat object under the overlap edges (on each side of the fuse holder) and lift until you clear the locking tabs.

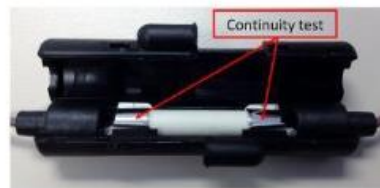

## 7.3 VAC Screen and LEDs do not illuminate

Possible Cause(s)	Action
VAC is in Hibernate mode	<ul style="list-style-type: none"> <li>Press the VAC's POWER button or turn the vehicle's ignition key to the ON position  (See Section 2 "Logging onto the VAC").</li> </ul>
Vehicle battery NOT connected	<ul style="list-style-type: none"> <li>Check that the vehicle battery is connected.</li> <li>Check the voltage level on the "1" (B+) and "9" (B-) pins of the VAC to vehicle cable.</li> </ul>
Inline fuse malfunction	<ul style="list-style-type: none"> <li>Open the fuse holders for the B+ and B- wires.</li> <li>Check continuity between the ends of the fuse using a multi-meter if continuity fails:                             <ul style="list-style-type: none"> <li>Make sure a short with the vehicle chassis is not blowing the fuse by checking for proper isolation.</li> <li>Replace fuse (with 3AB type 2A, 250V ceramic fuse)</li> </ul> </li> </ul>
VAC to vehicle cable damaged	<ul style="list-style-type: none"> <li>Use an ohmmeter to check resistance to verify cable integrity. <b>Note:</b> An "open" or zero reading indicates a damaged cable on the "B+" and "B-" wires.</li> <li>Replace the cable as needed and retest.</li> </ul>
Internal VAC malfunction	<ul style="list-style-type: none"> <li>Complete an RMA Request form (Appendix A).</li> <li>Call Powerfleet Support for the RMA number.</li> <li>Only the VAC should be returned for analysis /repair; Once the VAC is removed, the system MUST be hard bypassed to use vehicle. (See Appendix B for bypass instructions.)</li> </ul>



**Issue: VAC Sensor Wizard says “No Hub”**

Possible Cause(s)	Correction
VAC is not properly powering the Sensor Hub	<p>If Sensor Hub LED is <b>NOT</b> lit:</p> <ul style="list-style-type: none"> <li>Remove the Sensor Hub cable from VAC C102 port.</li> <li>Test voltage at C102 port using a voltmeter.                             <ul style="list-style-type: none"> <li>If voltage meets the following, replace the Sensor Hub:                                     <ul style="list-style-type: none"> <li>Pins 1 and 5: 5.3V</li> <li>Pins 2 and 5: 0V</li> <li>Pins 3 and 5: -5.8V</li> </ul> </li> <li>If voltage is outside the above range, replace the VAC. If the Sensor Hub LED is lit:</li> </ul> </li> <li>Test voltage at Sensor Hub OUT port using a voltmeter.                             <ul style="list-style-type: none"> <li>If voltage meets the following, replace the Sensor Hub:                                     <ul style="list-style-type: none"> <li>Pins 1 and 5: 5.3V</li> <li>Pins 2 and 5: 0V</li> <li>Pins 3 and 5: -5.8V</li> </ul> </li> <li>If voltage is outside the above range, replace the VAC.</li> </ul> </li> </ul>

**Issue: Sensor Hub LED is blinking RED-AMBER-GREEN repeatedly**

Possible Cause(s)	Correction
Sensor Hub firmware bug	Replace the Sensor Hub

## 9 SECTION 9: SELF-DIAGNOSTIC ERROR CODES

The Powerfleet system automatically diagnoses system errors. Errors can be monitored using reports in Powerfleet Vision Pro software (Refer to the Powerfleet Vision Pro training video). In addition, existing errors are indicated on the VAC screen display with a message and icon (see below) when no one is logged in. Icons are also displayed in the screen status header when a Standard or Master Operators are logged into a vehicle. The three error categories, based on risk to system functionality are: SHUTDOWN, FUNCTIONAL and REFERENCE.

ERROR CATEGORY DESCRIPTION	VAC SCREEN DISPLAY (STANDARD and MASTER operators)
----------------------------	---

**SHUTDOWN** errors lock out vehicles from use by Standard and Master operators, due to potential safety concerns.

If a VAC is NOT configured properly, an “Unconfigured” error message is displayed.

For other types of Shutdown errors, the VAC screen will display “Error”. For all Shutdown errors, the VAC screen will also display “call Maintenance”.

Only Maintenance operators can log into a VAC when a Shutdown error occurs.



**FUNCTIONAL** errors can limit system effectiveness and skew data. Such errors require immediate evaluation by a Maintenance operator.

The VAC screen will display “Error, Maintenance required now” when a Function error occurs.



**OPERATIONAL** error can occur if the vehicle sensors indicate the vehicle is in motion at the time of a login.

Then, the VAC:

1. Allows operators to logoff while the vehicle sensor is recording motion,
  2. Allows unauthorized operators to log in and use the vehicle,
  3. Allows any operator to use the vehicle without logging in.
  4. Prevent the VAC from locking out the vehicle for any reason.
- The Operational error clears itself once a subsequent login event occurs where the vehicle sensors indicate that the vehicle is idle at the time of login.



**REFERENCE** errors have little immediate effect on the system and do not require immediate attention. However, a Maintenance operator should evaluate all Reference errors at the end of the shift or workday. For Reference errors, the VAC screen will display “Error, Maintenance req. after Shift”.



**Note:** Vehicles in “Any ID” mode will not be subject to lockouts.

## Interpreting Error Codes

The example below illustrates how to interpret a VAC error message on the screen when logged in as a Maintenance operator.

The VAC screen message is displayed as follows: 00-Error Msg > 24 Hours (Refer to Hardware Guide)

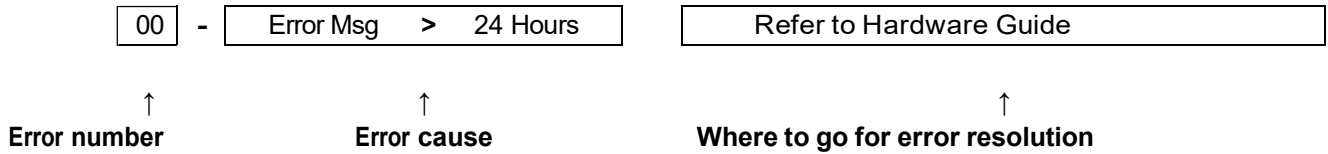

## Error Codes

### 00-Error Msg > 24Hrs (Refer to Hardware Guide)

[FUNCTIONAL] Appears after a reference error has been present on a vehicle for greater than 24 hours

Possible Cause(s)	Action
Reference error was not cleared by a Maintenance operator within 24 hours of the error creation.	<ul style="list-style-type: none"> <li>Log in to the VAC as a Maintenance operator and review/ address each error message that is displayed.</li> <li>To view the errors, select the "ERRORS" menu option and scroll up/ down.</li> </ul>

### 08-100% Motion Err (Refer to Hardware Guide)

[FUNCTIONAL] The VAC is sensing 100% motion while no one is logged in (the vehicle is unassigned) and the vehicle is not in ID Optional mode.

Possible Cause(s)	Action
Insufficient "BLU" (motion sensing) connection point	<ul style="list-style-type: none"> <li>Verify that the "BLU" wire is connected to the proper traction (motion) sensing circuit. Refer to the Powerfleet Installation Guide.</li> <li>Log in to the VAC as a Maintenance operator and re-run the configuration wizard (see Section 2)</li> </ul>
Failed fuse on "BLU" (motion sensing) wire	<ul style="list-style-type: none"> <li>Verify that the fuse for the "BLU" wire is not blown or missing.</li> <li>Repair as needed.</li> <li>Log in to the VAC as a Maintenance operator and re-run the configuration wizard (see Section 2).</li> </ul>

Incorrect motion values	<ul style="list-style-type: none"> <li>Log in to the VAC as a Maintenance operator and re-run the configuration wizard (see Section 2)</li> <li>Log in to the VAC and review the motion values (See “Defining ‘Motion’ Manually”).</li> <li>Adjust values as needed.</li> </ul>
Vehicle cable	<ul style="list-style-type: none"> <li>Use an ohmmeter to check resistance to verify cable integrity on the “BLU” wire. <b>Note:</b> An “open” or zero reading indicates a damaged cable.</li> <li>Replace the cable as needed and retest.</li> </ul>

### 09-Motion w/o Login (Refer to Hardware Guide)

[FUNCTIONAL] The VAC sensed motion while no one was logged in (unassigned) and the vehicle is not in ID Optional mode.

Possible Cause(s)	Action
Insufficient “BLU” (motion sensing) connection point	<ul style="list-style-type: none"> <li>Verify that the “BLU” wire is connected to the proper traction (motion) sensing circuit. Refer to the Powerfleet® Installation Guide.</li> <li>Wiring to the motor directly is a common cause for this issue on some vehicles; preferred locations include the throttle or pedal.</li> <li>Log in to the VAC as a Maintenance operator and re-run the configuration wizard (see Section 2)</li> </ul>
Failed fuse on “BLU” (motion sensing) wire	<ul style="list-style-type: none"> <li>Verify that the fuse for the “BLU” wire is not blown or missing.</li> <li>Repair as needed.</li> <li>Log in to the VAC as a Maintenance operator and re-run the configuration wizard (see Section 2)</li> </ul>
Incorrect motion values	<ul style="list-style-type: none"> <li>Log in to the VAC as a Maintenance operator and re-run the configuration wizard (see Section 2)</li> <li>Log in to the VAC and review the motion values (see: “Defining ‘Motion’ Manually”).</li> <li>Adjust values as needed.</li> </ul>
Vehicle cable	<ul style="list-style-type: none"> <li>Use an ohmmeter to check resistance check to verify cable integrity (an “open” or zero reading indicates a damaged cable) on the “BLU” wire.</li> <li>Replace the cable as needed and retest.</li> </ul>

### 10- 0% Motion (Refer to Hardware Guide)

[SHUTDOWN] The VAC is hard bypassed or external relay is not wired to prevent access when logged off.

Possible Cause(s)	Action
Insufficient “BLU” (motion sensing) connection point	<ul style="list-style-type: none"><li>• Verify that the “BLU” wire is connected to the proper traction (motion) sensing circuit. Refer to the Powerfleet Installation Guide.</li><li>• Log in to the VAC as a Maintenance operator and re-run the configuration wizard (see Section 2)</li></ul>
Failed fuse on “BLU” (motion sensing) wire	<ul style="list-style-type: none"><li>• Verify that the fuse for the “BLU” wire is not blown or missing.</li><li>• Repair as needed.</li><li>• Log in to the VAC as a Maintenance operator and re-run the configuration wizard (see Section 2)</li></ul>
“BRN” wire connection point (Internal combustion vehicles only)	<ul style="list-style-type: none"><li>• Verify that the “BRN” wire is connected to the proper engine on sensing circuit. Refer to the Powerfleet® Installation Guide.</li><li>• Log in to the VAC as a Maintenance operator and re-run the configuration wizard (see Section 2)</li></ul>
Incorrect motion values	<ul style="list-style-type: none"><li>• Log in to the VAC as a Maintenance operator and re-run the configuration wizard (see Section 2)</li><li>• Log in to the VAC and review the motion values (see: “Defining ‘Motion’ Manually”).</li><li>• Adjust values as needed.</li></ul>
Vehicle cable	<ul style="list-style-type: none"><li>• Use an ohmmeter to check resistance check to verify cable integrity on the “BLU” wire. <b>Note:</b> An “open” or zero reading indicates a damaged cable.</li><li>• Replace the cable as needed and retest.</li></ul>

### 11-Motion Config Er (Refer to Hardware Guide)

[SHUTDOWN] The motion threshold values are not configured correctly (too close).

Possible Cause(s)	Action
Insufficient “BLU” (motion sensing) connection point	<ul style="list-style-type: none"><li>• Verify that the “BLU” wire is connected to the proper traction (motion) sensing circuit. Refer to the Powerfleet Installation Guide.</li><li>• Wiring to the motor directly is a common cause for this issue on some vehicles; preferred locations include the throttle or pedal.</li></ul>

	<ul style="list-style-type: none"> <li>Log in to the VAC as a Maintenance operator and re-run the configuration wizard (see Section 2)</li> </ul>
Failed fuse on “BLU” (motion sensing) wire	<ul style="list-style-type: none"> <li>Verify that the fuse for the “BLU” wire is not blown or missing.</li> <li>Repair as needed.</li> <li>Log in to the VAC as a Maintenance operator and re-run the configuration wizard (see Section 2)</li> </ul>
Incorrect motion values	<ul style="list-style-type: none"> <li>Log in to the VAC as a Maintenance operator and re-run the configuration wizard (see Section 2)</li> <li>Log in to the VAC and review the motion values (See: “Defining ‘Motion’ Manually”).</li> <li>Adjust values as needed.</li> </ul>
Vehicle cable	<ul style="list-style-type: none"> <li>Use an ohmmeter to check resistance check to verify cable integrity on the “BLU” wire. <b>Note:</b> An “open” or zero reading indicates a damaged cable.</li> <li>Replace the cable as needed and retest.</li> </ul>

### 13-Impact Sensor Er (Refer to Hardware Guide)

[FUNCTIONAL] System reports no impact sensor is installed.

Possible Cause(s)	Action
Impact sensor connection	<ul style="list-style-type: none"> <li>Verify that the impact sensor is properly connected to the VAC (connector C103).</li> </ul>
Impact sensor cable damage	<ul style="list-style-type: none"> <li>Verify that the impact sensor cable is not damaged.</li> <li>Replace sensor as needed and retest.</li> </ul>
Impact sensor is not getting power from the VAC	<ul style="list-style-type: none"> <li>Verify that the VAC is supplying adequate voltage by unplugging the impact sensor connector and connecting a voltmeter to pin 1 (positive) and pin 8 (negative) on C103 of the VAC. The image at right shows how to read the pin layout and direction.</li> <li>You must have <math>5.5 \pm 0.5</math> volts DC.</li> <li>If the VAC is not supplying <math>5.5 \pm 0.5</math> VDC <ul style="list-style-type: none"> <li>Request an RMA (See Appendix A)</li> <li>Call Powerfleet’s Customer Service for an RMA number.</li> <li>Only the VAC should be returned for analysis/repair.</li> <li>Once VAC is removed, the system MUST be hard bypassed to use vehicle. Follow instructions on how to hard-bypass the system (See Appendix B).</li> </ul> </li> </ul>

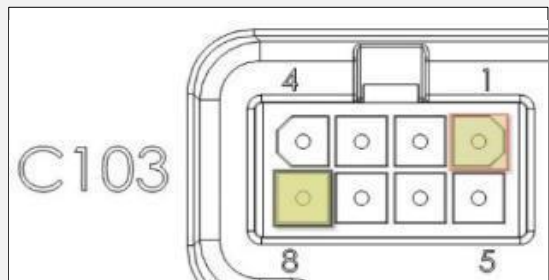

Faulty impact sensor	<ul style="list-style-type: none"> <li>• Request an RMA (See Appendix A)</li> <li>• Call Powerfleet’s Customer Service for an RMA number.</li> <li>• Only the Impact sensor should be returned for analysis/repair.</li> </ul>
----------------------	--

**14-SPI Error Low (Refer to Hardware Guide)**  
 [FUNCTIONAL] The VAC cable is picking up electrical noise causing SPI errors greater than 1% of the time.

Possible Cause(s)	Action
VAC Cable	<ul style="list-style-type: none"> <li>• Visually inspect the VAC cable to verify that the VAC cable is not damaged.</li> <li>• Replace the cable as needed.</li> </ul>
Electrical noise	<ul style="list-style-type: none"> <li>• Verify that the VAC cable is routed away from high electrical noise devices such as traction motors and contactors.</li> <li>• If chassis noise is present, reroute the cable and retest.</li> </ul>

**15- Run Configuration Wizard**  
 [SHUTDOWN] The configuration wizard was never run for the VAC that is currently installed on the vehicle.

Possible Cause(s)	Action
VAC configuration	<ul style="list-style-type: none"> <li>• Log in the to VAC as a Maintenance operator and re-run the configuration wizard (see Section 2)</li> </ul>

**17-ID Reader Error (Refer to Hardware Guide)**  
 [FUNCTIONAL] The communication between the integrated VAC iButton fob/ Access ID Card reader and the iButton/Access ID Card is not working correctly.

Possible Cause(s)	Action
iButton/ Access ID Card	<ul style="list-style-type: none"> <li>• Test the subject iButton/ Access ID Card on another vehicle’s ID reader.</li> <li>• If the iButton/ Access ID Card can be read, skip to the next troubleshooting step.</li> <li>• If iButton/ Access ID Card cannot be read, issue operator a new iButton/ Access ID Card and wait for the vehicle to synchronize. Remember to update the</li> <li>• operator’s access control profile in the software.</li> </ul>
Dirty iButton/ Access ID Card / reader and/or iButton/ Access ID Card.	<ul style="list-style-type: none"> <li>• Clean the metal surfaces of the iButton/ iButton reader and Access ID Card and retest.</li> </ul>

iButton/ Access ID Card reader error	<ul style="list-style-type: none"> <li>• Request an RMA (See Appendix A).</li> <li>• Call Powerfleet’s Customer Service for an RMA number.</li> <li>• Only the VAC should be returned for analysis/repair.</li> <li>• Once VAC is removed, the system MUST be hard bypassed to use vehicle.</li> <li>• Follow instructions on how to hard-bypass the system (See Appendix B).</li> <li>• Run “CloneVAC” on the new VAC (See Section 4 for instructions).</li> </ul>
--------------------------------------	---

**18-Low Internal Batt Power VAC for 1 Hr**  
 [FUNCTIONAL] The VAC’s backup battery voltage has fallen below 2.5 volts DC. If the VAC loses power during this error (if the vehicle battery is unplugged), operator authorizations will be lost, and a full synchronization will be required for operators to access the vehicle again.

Possible Cause(s)	Action
VAC battery not fully charged after initial install	<ul style="list-style-type: none"> <li>• Allow the VAC to charge the internal battery by powering up the VAC (keeping the vehicle battery connected) for at least 1 hour.</li> </ul>
VAC was powered off for extended period	<ul style="list-style-type: none"> <li>• Allow the VAC to charge the internal battery by powering up the VAC (keeping the vehicle battery connected) for at least 1 hour.</li> </ul>
Internal battery error	<ul style="list-style-type: none"> <li>• Request an RMA (See Appendix A).</li> <li>• Call Powerfleet’s Customer Service for an RMA number.</li> <li>• Only the VAC should be returned for analysis/repair.</li> <li>• Once VAC is removed, the system MUST be hard bypassed to use vehicle.</li> <li>• Follow instructions on how to hard-bypass the system (See Appendix B).</li> <li>• Run “CloneVAC” on the new VAC (See Section 4 for instructions).</li> </ul>

**19-Impact Cal Error (Refer to Hardware Guide)**  
 [FUNCTIONAL] VAC detects an impact sensor algorithm error.

Possible Cause(s)	Action
Impact sensor installation	<ul style="list-style-type: none"> <li>• Verify that the impact sensor is mounted. (Refer to the Powerfleet® Installation Guide retest).</li> <li>• If Error 19 persists:             <ul style="list-style-type: none"> <li>○ Request an RMA (See Appendix A)</li> <li>○ Call Powerfleet’s Customer Service for an RMA number.</li> <li>○ Only the Impact Sensor should be returned for analysis/repair.</li> </ul> </li> </ul>

## 20-Keypad PIC Err Contact IDSY

[FUNCTIONAL] The VAC has detected an internal error

Possible Cause(s)	Action
Internal VAC Error	<ul style="list-style-type: none"><li>• Request an RMA (See Appendix A).</li><li>• Call Powerfleet’s Customer Service for an RMA number.</li><li>• Only the VAC should be returned for analysis/repair.</li><li>• Once VAC is removed, the system MUST be hard bypassed to use vehicle.</li><li>• Follow instructions on how to hard-bypass the system (See Appendix B).</li><li>• Run “CloneVAC” on the new VAC (See Section 4 for instructions).</li></ul>

## 21-UI PIC Err Contact IDSY

[FUNCTIONAL] The VAC has detected an internal error

Possible Cause(s)	Action
Internal VAC Error	<ul style="list-style-type: none"><li>• Request an RMA (See Appendix A).</li><li>• Call Powerfleet’s Customer Service for an RMA number.</li><li>• Only the VAC should be returned for analysis/repair.</li><li>• Once VAC is removed, the system MUST be hard bypassed to use vehicle.</li><li>• Follow instructions on how to hard-bypass the system (See Appendix B).</li><li>• Run “CloneVAC” on the new VAC (See Section 4 for instructions).</li></ul>

## 22-PIB PIC Error Contact IDSY –

[FUNCTIONAL] The VAC has detected an internal error

Possible Cause(s)	Action
Internal VAC Error	<ul style="list-style-type: none"><li>• Request an RMA (See Appendix A).</li><li>• Call Powerfleet’s Customer Service for an RMA number.</li><li>• Only the VAC should be returned for analysis/repair.</li><li>• Once VAC is removed, the system MUST be hard bypassed to use vehicle.</li><li>• Follow instructions on how to hard-bypass the system (See Appendix B).</li><li>• Run “CloneVAC” on the new VAC (See Section 4 for instructions).</li></ul>

### 23-OUTPUT PIC Err Contact IDSY.

[FUNCTIONAL] The VAC has detected an internal error

Possible Cause(s)	Action
Internal VAC Error	<ul style="list-style-type: none"><li>• Request an RMA (See Appendix A).</li><li>• Call Powerfleet’s Customer Service for an RMA number.</li><li>• Only the VAC should be returned for analysis/repair.</li><li>• Once VAC is removed, the system MUST be hard bypassed to use vehicle.</li><li>• Follow instructions on how to hard-bypass the system (See Appendix B).</li><li>• Run “CloneVAC” on the new VAC (See Section 4 for instructions).</li></ul>

### 24-VAC Memory Full (Refer to Hardware Guide)

[FUNCTIONAL] The internal VAC memory is full.

Possible Cause(s)	Action
VAC communication	<ul style="list-style-type: none"><li>• Drive the vehicle near the Wireless Asset Manager (WAM), or Access Point for Wi-Fi systems, and wait 1-30 minutes.</li></ul>
VAC error	<ul style="list-style-type: none"><li>• Verify that other VACs synchronize with the system correctly by driving another vehicle near the Wireless Asset Manager (WAM) or Wi-Fi Access Point, waiting 2 minutes, then checking the “Vehicle Configuration Status” report in Powerfleet Vision Pro software to verify Last Detected Date is the current date.</li><li>• If other VACs are synchronizing, request an RMA (See Appendix A)</li><li>• Call Powerfleet’s Customer Service for an RMA number.<ul style="list-style-type: none"><li>○ Only the VAC should be returned for analysis/repair.</li><li>○ Once VAC is removed, the system MUST be hard bypassed to use vehicle.</li><li>○ Follow instructions on how to hard-bypass the system. (See Appendix B)</li><li>○ Run “CloneVAC” on the new VAC (see Section 4 for instructions)</li></ul></li></ul>
WAM/Modem communication	<ul style="list-style-type: none"><li>• Verify that the WAM and Modem LEDs match the recommended state. Refer to the Cellular WAM Installation Guide.</li><li>• If the LEDs do not match the recommended state, reboot the WAM by unplugging the WAM, waiting 30 seconds and plugging the WAM back in. Verify that the WAM and Modem LEDs match the recommended state. Refer to the Cellular WAM Installation Guide.</li><li>• If rebooting the WAM does not work<ul style="list-style-type: none"><li>○ Request an RMA (See Appendix A)</li><li>○ Call Powerfleet’s Customer Service for an RMA number.</li><li>○ Only the WAM should be returned for analysis/repair.</li></ul></li></ul>

Wi-Fi communication	<ul style="list-style-type: none"> <li>• Verify the VAC is connected to the server.</li> <li>• Update the Wi-Fi connection profile (SSID, Security method, credentials, etc.)</li> <li>• Turn the Wi-Fi off.</li> <li>• Turn the Wi-Fi on.</li> <li>• If the VAC still does not communicate and the Wi-Fi status indicator displays no bars: <ul style="list-style-type: none"> <li>○ Request an RMA (See Appendix A)</li> <li>○ Call Powerfleet’s Customer Service for an RMA number.</li> <li>○ Only the WAM should be returned for analysis/repair.</li> </ul> </li> </ul>
---------------------	---

**25-Unrecognized WAM (Refer to Hardware Guide)**  
[FUNCTIONAL] The VAC is receiving messages from other facilities

Possible Cause(s)	Action
WAM communication cross talk with another facility	<ul style="list-style-type: none"> <li>• Verify VAC's Facility ID configuration matches the one provided for the site and matches the other VACs at the site.</li> <li>• Contact Powerfleet Customer Service</li> </ul>

**26-Comm Error (Refer to Hardware Guide)**  
[FUNCTIONAL] The server has not heard from the VAC for at least 5 days

Possible Cause(s)	Action
VAC communication	<ul style="list-style-type: none"> <li>• Drive the vehicle near the Wireless Asset Manager (WAM), or Access Point for Wi-Fi systems, and wait 1-30 minutes.</li> </ul>
VAC error	<ul style="list-style-type: none"> <li>• Verify that other VACs synchronize with the system correctly by driving another vehicle near the Wireless Asset Manager (WAM) or Wi-Fi Access Point, waiting 2 minutes, then checking the “Vehicle Configuration Status” report in Powerfleet Vision Pro software to verify Last Detected Date is the current date.</li> <li>• If other VACs are synchronizing <ul style="list-style-type: none"> <li>○ Request an RMA (See Appendix A)</li> <li>○ Call Powerfleet’s Customer Service for an RMA number.</li> <li>○ Only the VAC should be returned for analysis/ repair.</li> <li>○ Once VAC is removed, the system MUST be hard bypassed to use vehicle.</li> <li>○ Follow instructions on how to hard-bypass the system. (See Appendix B)</li> <li>○ Run “CloneVAC” on the new VAC (See Section 4 for instructions)</li> </ul> </li> </ul>

WAM/Modem communication	<ul style="list-style-type: none"> <li>• Verify that the WAM and Modem LEDs match the recommended state. Refer to the Cellular WAM Installation Guide.</li> <li>• If the LEDs do not match the recommended state, reboot the WAM by unplugging the WAM, waiting 30 seconds and plugging the WAM back in. Verify that the WAM and Modem LEDs match the recommended state. Refer to the Cellular WAM Installation Guide.</li> <li>• If rebooting the WAM does not work <ul style="list-style-type: none"> <li>○ Request an RMA (See Appendix A)</li> <li>○ Call Powerfleet’s Customer Service for an RMA number.</li> <li>○ Only the WAM should be returned for analysis/ repair.</li> </ul> </li> </ul>
Wi-Fi communication	<ul style="list-style-type: none"> <li>• Verify the VAC is connected to the server.</li> <li>• Update the Wi-Fi connection profile (SSID, Security method, credentials, etc.)</li> <li>• Turn the Wi-Fi off.</li> <li>• Turn the Wi-Fi on.</li> <li>• If the VAC still does not communicate and the Wi-Fi status indicator displays no bars: <ul style="list-style-type: none"> <li>○ Request an RMA (See Appendix A)</li> <li>○ Call Powerfleet’s Customer Service for an RMA number.</li> <li>○ Only the WAM should be returned for analysis/ repair.</li> </ul> </li> </ul>

**27-Impact Cal Error (Refer to Hardware Guide)**  
**[SHUTDOWN] Impact sensor test failed during sensor calibration.**

Possible Cause(s)	Action
Impact sensor connection	Verify that the impact sensor is properly connected to the VAC (connector C103).
Impact sensor cable damage	<ul style="list-style-type: none"> <li>• Verify that the impact sensor cable is not damaged.</li> <li>• Replace sensor as needed and retest.</li> </ul>
Impact sensor is not getting power from the VAC	<ul style="list-style-type: none"> <li>• Verify that the VAC is supplying adequate voltage by unplugging the impact sensor connector and connecting a voltmeter to pin 1 (positive) and pin 8 (negative) on C103 of the VAC. The image at right shows how to read the pin layout and direction.</li> <li>• You must have 5.5 ± 0.5 volts DC.</li> <li>• If the VAC is not supplying 5.5 ± 0.5 VDC <ul style="list-style-type: none"> <li>○ Request an RMA (See Appendix A)</li> <li>○ Call Powerfleet’s Customer Service for an RM number.</li> <li>○ Only the VAC should be returned for analysis./repair.</li> </ul> </li> <li>○ Once VAC is removed, the system MUST be hard bypassed to use vehicle.</li> <li>• Follow instructions on how to hard-bypass the system. (See Appendix B)</li> </ul>
Faulty impact sensor	<ul style="list-style-type: none"> <li>• Request an RMA (See Appendix A)</li> <li>• Call Powerfleet’s Customer Service for an RMA number.</li> <li>• Only the Impact sensor should be returned for analysis/ repair.</li> </ul>

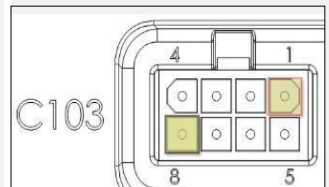

**28-FWD Motion Error (Refer to Hardware Guide) [SHUTDOWN]** The VAC did not correctly detect forward motion during the configuration wizard phase when asked to move the vehicle forward for three second.

Possible Cause(s)	Action
Speeding during drive forward test	<ul style="list-style-type: none"> <li>Log in to the VAC as a Maintenance operator and re-run the configuration wizard (see Section 2).</li> <li>Drive slowly where directed</li> </ul>
Insufficient “BLU” (motion sensing) connection point	<ul style="list-style-type: none"> <li>Verify that the “BLU” wire is connected to the proper traction (motion) sensing circuit. Refer to the Powerfleet Installation Guide.</li> <li>Log in to the VAC as a Maintenance operator and re-run the configuration wizard (see Section 2)</li> </ul>
Failed fuse on “BLU” (motion sensing) wire	<ul style="list-style-type: none"> <li>Verify that the fuse for the “BLU” wire is not blown or missing.</li> <li>Repair as needed.</li> <li>Log in to VAC as a Maintenance operator and re-run the configuration wizard (see Section 2)</li> </ul>
“BRN” wire connection point (Internal combustion vehicles only)	<ul style="list-style-type: none"> <li>Verify that the “BRN” wire is connected to the proper traction (motion) sensing circuit. Refer to the Powerfleet® Installation Guide.</li> <li>Log in to VAC as a Maintenance operator and re-run the configuration wizard (see Section 2)</li> </ul>
Incorrect forward motion values	<ul style="list-style-type: none"> <li>Log in to VAC as a Maintenance operator and re-run the configuration wizard (see Section 2).</li> <li>Log in to the VAC and review the motion values (see: “Defining ‘Motion’ Manually”).</li> <li>Adjust values as needed.</li> </ul>
Vehicle cable	<ul style="list-style-type: none"> <li>Use an ohmmeter to check resistance to verify cable integrity (an “open” or zero reading indicates a damaged cable) on the “BLU” wire.</li> <li>Replace the cables as needed and retest.</li> </ul>

**29-RVS Motion Error (Refer to Hardware Guide)**

[SHUTDOWN] The VAC did not correctly detect reverse motion during the configuration wizard phase when asked to move the vehicle in reverse for three second.

Possible Cause(s)	Action
-------------------	--------

Speeding during drive forward test	<ul style="list-style-type: none"> <li>Log in to the VAC as a Maintenance operator and re-run the configuration wizard (see Section 2).</li> <li>Drive slowly where directed.</li> </ul>
Insufficient “BLU” (motion sensing) connection point	<ul style="list-style-type: none"> <li>Verify that the “BLU” wire is connected to the proper traction (motion) sensing circuit. Refer to the Powerfleet Installation Guide.</li> <li>Log in to the VAC as a Maintenance operator and re-run the configuration wizard (see Section 2).</li> </ul>
Failed fuse on “BLU” (motion sensing) wire	<ul style="list-style-type: none"> <li>Verify that the fuse for the “BLU” wire is not blown or missing.</li> <li>Repair as needed.</li> <li>Log in to the VAC as a Maintenance operator and re-run the configuration wizard (see Section 2).</li> </ul>
“BRN” wire connection point (Internal combustion vehicles only)	<ul style="list-style-type: none"> <li>Verify that the “BRN” wire is connected to the proper Engine-On Signal. Refer to the Powerfleet® Installation Guide.</li> <li>Log in to the VAC as a Maintenance operator and re-run the configuration wizard (See Section 2).</li> </ul>
Incorrect reverse motion values	<ul style="list-style-type: none"> <li>Log in to the VAC as a Maintenance operator and re-run the configuration wizard (see Section 2).</li> <li>Log in to the VAC and review the motion values (see: “Defining ‘Motion’ Manually”).</li> <li>Adjust values as needed.</li> </ul>
Vehicle cable	<ul style="list-style-type: none"> <li>Use an ohmmeter to check resistance to verify cable integrity (an “open” or zero reading indicates a damaged cable) on the “BLU” wire.</li> <li>Replace the cable as needed and retest.</li> </ul>
Vehicle has separate forward and reverse motors	<ul style="list-style-type: none"> <li>Use a dual-diode solution to split the “BLU” wire into 2 wires to sense when either of the separate drive motors are active.</li> </ul>

### 30- FWD Motion Error (Refer to Hardware Guide)

[SHUTDOWN] VAC does not sense consistent forward motion.

Possible Cause(s)	Action
Speeding during drive forward test	<ul style="list-style-type: none"> <li>Log in to the VAC as a Maintenance operator and re-run the configuration wizard (see Section 2).</li> <li>Drive slowly where directed.</li> </ul>

Insufficient “BLU” (motion sensing) connection point	<ul style="list-style-type: none"> <li>• Verify that the “BLU” wire is connected to the proper traction (motion) sensing circuit. Refer to the Powerfleet Installation Guide.</li> <li>• Log in to the VAC as a Maintenance operator and re-run the configuration wizard (see Section 2)</li> </ul>
Failed fuse on “BLU” (motion sensing) wire	<ul style="list-style-type: none"> <li>• Verify that the fuse for the “BLU” wire is not blown or missing.</li> <li>• Repair as needed.</li> <li>• Log in to the VAC as a Maintenance operator and re-run the configuration wizard (see Section 2)</li> </ul>
Incorrect forward motion values	<ul style="list-style-type: none"> <li>• Log in to the VAC as a Maintenance operator and re-run the configuration wizard (see Section 2).</li> <li>• Log in to the VAC and review the motion values (see: “Defining ‘Motion’ Manually”).</li> <li>• Adjust values as needed.</li> </ul>
Vehicle cable	<ul style="list-style-type: none"> <li>• Use an ohmmeter to check resistance to verify cable integrity (an “open” or zero reading indicates a damaged cable) on the “BLU” wire.</li> <li>• Replace the cable as needed and retest.</li> </ul>

### 31-RVS Motion Error (Refer to Hardware Guide)

[SHUTDOWN] VAC does not sense consistent reverse motion.

Possible Cause(s)	Action
Speeding during drive forward test	<ul style="list-style-type: none"> <li>• Log in to the VAC as a Maintenance operator and re-run the configuration wizard (see Section 2).</li> <li>• Drive slowly where directed.</li> </ul>
Insufficient “BLU” (motion sensing) connection point	<ul style="list-style-type: none"> <li>• Verify that the “BLU” wire is connected to the proper traction (motion) sensing circuit. Refer to the Powerfleet Installation Guide.</li> <li>• Log in to the VAC as a Maintenance operator and re-run the configuration wizard (see Section 2)</li> </ul>
Failed fuse on “BLU” (motion sensing) wire	<ul style="list-style-type: none"> <li>• Verify that the fuse for the “BLU” wire is not blown or missing.</li> <li>• Repair as needed.</li> <li>• Log in to the VAC as a Maintenance operator and re-run the configuration wizard (see Section 2)</li> </ul>

Incorrect reverse motion values	<ul style="list-style-type: none"> <li>• Log in to the VAC as a Maintenance operator and re-run the configuration wizard (see Section 2).</li> <li>• Log in to the VAC and review the motion values (see: “Defining ‘Motion’ Manually”).</li> <li>• Adjust values as needed.</li> </ul>
---------------------------------	---

**32-Seat Switch Error (Refer to Hardware Guide)**  
 [SHUTDOWN] Seat/deadman switch error occurred in VAC config.

Possible Cause(s)	Action
Accidental operator error during configuration	<ul style="list-style-type: none"> <li>• Run the installation wizard again. Ensure that you are not on the seat switch or dead man switch when instructed while selecting “NEXT” during the configuration wizard.</li> </ul>
"2" and "4" wire connection points (and "6" and "8" for internal combustion vehicles)	<ul style="list-style-type: none"> <li>• Verify that the "2" and "4" connection points (and "6" and "8" for internal combustion vehicles) are connected to a circuit that will inhibit the vehicle from moving (or shut the vehicle down for internal combustion vehicles) when you are not logged into the VAC. Refer to the Powerfleet Installation Guide for recommended connection points.</li> <li>• Log in to the VAC as a Maintenance operator and re-run the configuration wizard (see Section 2)</li> </ul>

**33-Access Relay Err (Refer to Hardware Guide)**  
 [SHUTDOWN] During the “disable access control” test, the VAC did not disable the engine as designed.

Possible Cause(s)	Action
Verify the relay is working.  Verify your connection point.	<ul style="list-style-type: none"> <li>• User your multimeter to verify you see 12 volts when the relay is toggled and 0 volts when not toggled.               <ul style="list-style-type: none"> <li>○ If not, Request an RMA (See Appendix A)</li> </ul> </li> <li>• Verify your access control point connection.</li> </ul>

**34-Idle Motion Error (Refer to Hardware Guide)**  
 [SHUTDOWN] VAC detects motion when vehicle is idle.

Possible Cause(s)	Action
-------------------	--------

Accidental operator error during configuration	<ul style="list-style-type: none"> <li>Run installation wizard again. Ensure that you are not on the seat switch or deadman switch when instructed while selecting “NEXT” during the configuration wizard.</li> </ul>
Insufficient “BLU” (motion sensing) connection point	<ul style="list-style-type: none"> <li>Verify that the “BLU” wire is connected to the proper traction (motion) sensing circuit. Refer to the Powerfleet Installation Guide.</li> <li>Log in to the VAC as a Maintenance operator and re-run the configuration wizard (see Section 2)</li> </ul>
Failed fuse on “BLU” (motion sensing) wire	<ul style="list-style-type: none"> <li>Verify that the fuse for the “BLU” wire is not blown or missing.</li> <li>Repair as needed.</li> <li>Log in to the VAC as a Maintenance operator and re-run the configuration wizard (see Section 2)</li> </ul>
Incorrect idle motion values	<ul style="list-style-type: none"> <li>Log in to the VAC as a Maintenance operator and re-run the configuration wizard (see Section 2).</li> <li>Log in to the VAC and review the motion values (See “Defining ‘Motion’ Manually”).</li> <li>Adjust values as needed.</li> </ul>
Vehicle cable	<ul style="list-style-type: none"> <li>Use an ohmmeter to check resistance to verify cable integrity (an “open” or zero reading indicates a damaged cable) on the “BLU” wire.</li> <li>Replace the cable as needed and retest.</li> </ul>

### 35-Idle Motion Error (Refer to Hardware Guide)

[SHUTDOWN] The VAC has detected an idle threshold that is not within the specified range of 20.

Possible Cause(s)	Action
Insufficient “BLU” (motion sensing) connection point	<ul style="list-style-type: none"> <li>Verify that the “BLU” wire is connected to the proper traction (motion) sensing circuit. Refer to the Powerfleet Installation Guide.</li> <li>Log in to the VAC as a Maintenance operator and re-run the configuration wizard (see Section 2)</li> </ul>
Failed fuse on “BLU” (motion sensing) wire	<ul style="list-style-type: none"> <li>Verify that the fuse for the “BLU” wire is not blown or missing.</li> <li>Repair as needed.</li> <li>Log in to the VAC as a Maintenance operator and re-run the configuration wizard (see Section 2)</li> </ul>

<p>“BRN” wire connection point (Internal combustion vehicles only)</p>	<ul style="list-style-type: none"> <li>• Verify that the “BRN” wire is connected to the proper Engine-On connection. Refer to the Powerfleet® Installation Guide.</li> <li>• Log in to the VAC as a Maintenance operator and re-run the configuration wizard (see Section 2)</li> </ul>
<p>Incorrect idle motion values</p>	<ul style="list-style-type: none"> <li>• Log in to the VAC as a Maintenance operator and re-run the configuration wizard (see Section 2).</li> <li>• Log in to the VAC and review the motion values (see: “Defining ‘Motion’ Manually”).</li> <li>• Adjust values as needed.</li> </ul>
<p>Vehicle cable</p>	<ul style="list-style-type: none"> <li>• Use an ohmmeter to check resistance to verify cable integrity (an “open” or zero reading indicates a damaged cable) on the “BLU” and “BRN” wires.</li> <li>• Replace the cable as needed and retest.</li> </ul>

**36-Impact sensor Er (Refer to Hardware Guide)**  
 [FUNCTIONAL] The impact sensor has experienced unrecoverable errors.

Possible Cause(s)	Action
-------------------	--------

<p>Disconnected impact sensor</p>	<ul style="list-style-type: none"> <li>• Verify that impact sensor is installed on the specified vehicle. If not, and it is uninstalled intentionally, then you must either re-run Install Wizard (to disable sensing at the VAC) or disable Impact Sensing for that vehicle using Powerfleet Vision Pro.</li> <li>• If the sensor is present but unplugged, then plug sensor back in. Identify how it was disconnected and address the root cause (e.g., no service loop/pulled too tight; cable connector cover missing on VAC Bracket, etc.)</li> <li>• Verify that sensor is working using the Hardware-&gt;Impact screen. X/Y readings should be 0.0 +/- 0.2G with R readings between 70 and 90 on both axes. If not, sensor may be malfunctioning.</li> </ul>
<p>Malfunctioning impact sensor</p>	<ul style="list-style-type: none"> <li>• Request an RMA (See Appendix A)</li> <li>• Mounting using screws or non-Powerfleet-provided tape; Re-mount using provided tape.</li> <li>• Make sure that no other object is 'bouncing' on top of sensor during normal driving.</li> <li>• Make sure that mounting location avoids positioning right near vehicle wheels or other surfaces prone to repetitive vibration while driving.</li> <li>• Call Powerfleet's Customer Service for an RMA number.</li> <li>• Only the impact sensor should be returned for analysis/repair.</li> <li>• Once the impact sensor is removed, the system will display error #13. This error can be ignored until the impact sensor is replaced.</li> </ul>

**37-Memory Error (Refer to Hardware Guide)**  
 [FUNCTIONAL] The VAC's internal memory has been lost.

Possible Cause(s)	Action
<p>Backup battery is/was too low (Error #18)</p>	<ul style="list-style-type: none"> <li>• Follow troubleshooting steps for error #18</li> </ul>
<p>Internal memory corruption</p>	<ul style="list-style-type: none"> <li>• Request an RMA (See Appendix A)</li> <li>• Call Powerfleet's Customer Service for an RMA number.</li> <li>• Only the VAC should be returned for analysis/repair.</li> <li>• Once VAC is removed, the system MUST be hard bypassed to use vehicle.</li> <li>• Follow instructions on how to hard-bypass the system. (See Appendix B)</li> <li>• Run "CloneVAC" on the new VAC (See Section 4 for instructions)</li> </ul>

### 38-Access Relay Err (Refer to Hardware Guide)

[SHUTDOWN] During the “disable access control” test, the VAC did not disable the engine as designed.

Possible Cause(s)	Action
Verify the relay is working.  Verify your connection point.	<ul style="list-style-type: none"><li>• User your multimeter to verify you see 12 volts when the relay is toggled and 0 volts when not toggled.<ul style="list-style-type: none"><li>○ If not, Request an RMA (See Appendix A).</li></ul></li><li>• Verify your access control point connection.</li></ul>

### 39-Forkload Config Er See Hardware Guide

[FUNCTIONAL] The forkload sensor has not been calibrated successfully.

Possible Cause(s)	Action
Forkload sensor not calibrated	<ul style="list-style-type: none"><li>• Log in to the VAC as a Maintenance operator and re-run the Sensors wizard from the Install menu.</li><li>• Follow the load configuration instructions.</li></ul>

### 40-Forkload Config Er See Hardware Guide

[FUNCTIONAL] The forkload sensor has not been calibrated successfully.

Possible Cause(s)	Action
Forkload sensor has a bad installation or calibration	<ul style="list-style-type: none"><li>• Check the load sensor installation and wiring to the sensor hub.</li><li>• Log in to the VAC as a Maintenance operator and re-run the Sensors wizard from the Install menu.</li><li>• Follow the load configuration instructions.</li></ul>

### 41-Travel Zero Error (Refer to Hardware Guide)

[REFERENCE] The travel sensor is reporting zero when the motion motor sensor indicates motion.

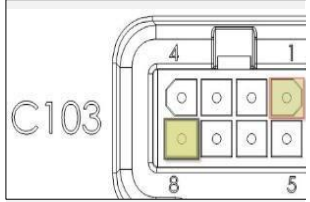
Possible Cause(s)	Action
Impact sensor connection	<ul style="list-style-type: none"> <li>Verify that the impact sensor is properly connected to the VAC (connector C103).</li> <li>Log in to the VAC as a Maintenance operator and re-run the configuration wizard (see Section 2)</li> </ul>
Impact sensor cable damage	<ul style="list-style-type: none"> <li>Verify that the impact sensor cable is not damaged.</li> <li>Replace sensor as needed and retest.</li> </ul>
Impact sensor is not getting power from the VAC	<ul style="list-style-type: none"> <li>Verify that the VAC is supplying adequate voltage by unplugging the impact sensor connector and connecting a voltmeter to pin 1 (positive) and pin 8 (negative) on C103 of the VAC. The image at right shows how to read the pin layout and direction.  </li> <li>You must have <math>5.5 \pm 0.5</math> volts DC. <ul style="list-style-type: none"> <li>If the VAC is not supplying <math>5.5 \pm 0.5</math> VDC <ul style="list-style-type: none"> <li>Request an RMA (See Appendix A)</li> <li>Call Powerfleet's Customer Service for an RMA number.</li> <li>Only the VAC should be returned for analysis/repair.</li> <li>Once VAC is removed, the system MUST be hard bypassed to use vehicle. Follow instructions on how to hard-bypass the system. (See Appendix B)</li> </ul> </li> </ul> </li> </ul>
Impact sensor mounting compromised	<ul style="list-style-type: none"> <li>Verify that the impact sensor is securely mounted to the vehicle chassis near the vehicle's center of gravity.</li> </ul>
Faulty impact sensor	<ul style="list-style-type: none"> <li>Request an RMA (See Appendix A)</li> <li>Call Powerfleet's Customer Service for an RMA number.</li> <li>Only the Impact sensor should be returned for analysis/repair.</li> </ul>
Motion sensor reporting motion incorrectly	See error code 11

#### 42-Travel Sensor Err (Refer to Hardware Guide)

[REFERENCE] The travel sensor is reporting significantly more or significantly less than the motion motor sensor indicates motion.

Possible Cause(s)	Action
Impact sensor connection	<ul style="list-style-type: none"> <li>Verify that the impact sensor is properly connected to the VAC (connector C103).</li> <li>Log in to the VAC as a Maintenance operator and re-run the configuration wizard (see Section 2)</li> </ul>
Impact sensor cable damage	<ul style="list-style-type: none"> <li>Verify that the impact sensor cable is not damaged.</li> <li>Replace sensor as needed and retest.</li> </ul>

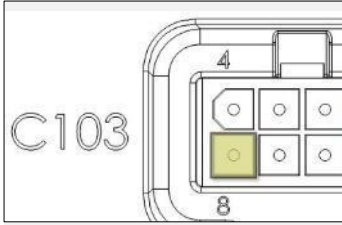
<p>Impact sensor is not getting power from the VAC</p>	<ul style="list-style-type: none"> <li>• Verify that the VAC is supplying adequate voltage by unplugging the impact sensor connector and connecting a voltmeter to pin 1 (positive) and pin 8 (negative) on C103 of the VAC. The image at right shows how to read the pin layout and direction.</li> <li>• You must have 5.5 ± 0.5 volts DC.</li> </ul>	
<p>Impact sensor mounting compromised</p>	<ul style="list-style-type: none"> <li>• If the VAC is not supplying 5.5 ± 0.5 VDC <ul style="list-style-type: none"> <li>○ Request an RMA (See Appendix A)</li> <li>○ Call Powerfleet’s Customer Service for an RMA number.</li> <li>○ Only the VAC should be returned for analysis/repair.</li> <li>○ Once VAC is removed, the system MUST be hard bypassed to use vehicle. Follow instructions on how to hard-bypass the system. (See Appendix B)</li> </ul> </li> </ul>	
<p>Faulty impact sensor</p>	<ul style="list-style-type: none"> <li>• Verify that the impact sensor is securely mounted to the vehicle chassis near the vehicle’s center of gravity.</li> </ul>	
<p>Motion sensor reporting motion incorrectly</p>	<ul style="list-style-type: none"> <li>• Request an RMA (See Appendix A)</li> <li>• Call Powerfleet’s Customer Service for an RMA number.</li> <li>• Only the Impact sensor should be returned for analysis/repair.</li> </ul>	
<p>Motion sensor reporting motion incorrectly</p>	<ul style="list-style-type: none"> <li>• See error code 11</li> </ul>	

**43-VAC Too Hot Move to Cooler Area – [FUNCTIONAL]** The VAC temperature has increased to levels that can damage the internal components.

Possible Cause(s)	Action
<p>Ambient temperature is over 150°F</p>	<ul style="list-style-type: none"> <li>• Move the vehicle to a location with a lower ambient temperature until the VAC cools down.</li> </ul>

**44-VAC Too Cold, Move to Warmer Area – [FUNCTIONAL]** The VAC temperature has decreased to levels that can damage the internal components.

Possible Cause(s)	Action
<p>Ambient temperature is below -10°F</p>	<ul style="list-style-type: none"> <li>• Move the vehicle to a location with a higher ambient temperature until the VAC warms up.</li> </ul>

#### 45-Serial Data Error (Refer to Hardware Guide)

[FUNCTIONAL] The serial data communication (OEM CAN, etc.) has too many invalid packets.

Possible Cause(s)	Action
Serial/CAN cable connection compromised	<ul style="list-style-type: none"><li>• Verify that the Serial/CAN cable is properly connected to both the Serial/CAN connection in the vehicle and the C102 connection on the VAC.</li><li>• Verify that the Serial/CAN cable is not damaged</li></ul>
Serial/CAN not communicating from vehicle	<ul style="list-style-type: none"><li>• See vehicle manufacturer's troubleshooting guide.</li></ul>

#### 46-VAC Button Error (Refer to Hardware Guide)

[FUNCTIONAL] One of the VAC keypad buttons is stuck in the 'pressed' position.

Possible Cause(s)	Action
Keypad malfunction	<ul style="list-style-type: none"><li>• Request an RMA (See Appendix A)</li><li>• Call Powerfleet's Customer Service for an RMA number.</li><li>• Only the VAC should be returned for analysis/repair.</li><li>• Once VAC is removed, the system MUST be hard bypassed to use vehicle.</li><li>• Follow instructions on how to hard-bypass the system. (See Appendix B)</li><li>• Run "CloneVAC" on the new VAC (see Section 4 for instructions)</li></ul>

#### 47-Facility Code Error (Refer to Hardware Guide)

[FUNCTIONAL] The facility ID entered in the VAC does not match the facility ID being transmitted by the currently in-range system.

Possible Cause(s)	Action
Incorrect facility ID	<ul style="list-style-type: none"><li>• Update the VAC's facility ID.<ul style="list-style-type: none"><li>○ Log into the VAC as a Maintenance operator</li><li>○ Navigate to the Access &gt; FacilityID screen.</li><li>○ Enter the facility ID provided by Powerfleet Support</li></ul></li></ul>
Multiple facilities have overlapping wireless coverage	<ul style="list-style-type: none"><li>• Verify the Server IP and Port are correct.</li><li>• Contact Powerfleet Support</li></ul>

#### 48-Wi-Fi FC IP Port Err (Refer to Hardware Guide)

[FUNCTIONAL] The facility ID is zero or the facility ID entered in the VAC does not match the facility ID being transmitted by the currently in-range system.

Possible Cause(s)	Action
Incorrect facility ID	<ul style="list-style-type: none"><li>• Update the VAC's Facility ID<ul style="list-style-type: none"><li>○ Log into the VAC as a Maintenance operator</li><li>○ Navigate to the Access &gt; FacilityID screen.</li><li>○ Enter the facility ID provided by Powerfleet Support</li></ul></li><li>• Could also be an Incorrect Server IP or Port; Verify this also.</li></ul>
Multiple facilities have overlapping wireless coverage	<ul style="list-style-type: none"><li>• Contact Powerfleet Support</li></ul>

#### 49-Output Alert Err (Refer to Hardware Guide)

[REFERENCE] A Maintenance operator indicated during the Sensor Install Wizard that the output alert (horn, alarm, strobe light, etc.) was not working.

Possible Cause(s)	Action
Wizard selection mistake	<ul style="list-style-type: none"><li>• Log in to the VAC as a Maintenance operator and re-run the Sensor Install wizard. Refer to System Installation Guide.</li><li>• Verify that the "Output Alert" feature in the Sensor Install Wizard is assigned to VIM "107."</li><li>• Select "Yes" after you witness the output alert working on the 'External Indicator' screen.</li></ul>
Sensor connection	<ul style="list-style-type: none"><li>• Verify that the Sensor Hub is properly connected to the VAC (connector C102).</li><li>• Verify that the sensor cable is connected to the VIM6/7 port on the Sensor Hub.</li><li>• Verify that the RED and BLACK wires of the sensor cable are connected the sensor or relay (refer to system installation guide).</li></ul>

Sensor Hub damaged	<ul style="list-style-type: none"> <li>• Verify the Sensor Hub LED color (orange or green indicates it is working).</li> <li>• Verify that other sensors are failing as well.</li> <li>• Request an RMA (refer to Appendix A in this document).</li> <li>• Call Powerfleet’s Customer Service for an RMA number.</li> <li>• Only the VAC should be returned for analysis/repair.</li> <li>• Once VAC is removed, the system MUST be hard bypassed to use vehicle.</li> <li>• Follow instructions on how to hard-bypass the system. (See Appendix B)</li> </ul>
Output alert sensor is not working	<ul style="list-style-type: none"> <li>• Repair or replace sensor or sensor components</li> </ul>

**50-Internal Memory Corruption/Err**  
 [FUNCTIONAL] VAC memory error.

Possible Cause(s)	Action
VAC malfunction	<ul style="list-style-type: none"> <li>• If this occurs, try clearing it once. If the error returns on the same VAC, the VAC requires an RMA. Please be sure to indicate that it is being returned for this error.</li> <li>• Log in to the VAC as a Maintenance operator and navigate to the Error menu.</li> <li>• Clear the error and if the error reappears,               <ul style="list-style-type: none"> <li>○ Request an RMA Request (See Appendix A)</li> <li>○ Call Powerfleet’s Customer Service for an RMA number.</li> <li>○ Only the VAC should be returned for analysis/repair.</li> <li>○ Once the VAC is removed, the system MUST be hard bypassed to use the vehicle.</li> <li>○ Follow instructions on how to hard-bypass the system. (See Appendix B) and check to see if it reappears</li> </ul> </li> </ul>

**51-Wrong VAC FW Contact IDSY**  
 [FUNCTIONAL] VAC was configured for PWM access, and the firmware does not support this feature

Action
<ul style="list-style-type: none"> <li>• If this occurs, the VAC needs to be upgraded to the latest version of firmware.</li> </ul>

### 52-Wi-Fi Config Err Contact IDSY

[FUNCTIONAL] VAC was configured for Proprietary or TLS data encryption, but the site is programmed to connect to does not support that data encryption.

#### Action

- If this occurs, the Wi-Fi data encryption method needs to be changed in the VAC (if this appears on only a couple VACs) or in the software license (if this occurs on all VACs).

### 53-Invalid Region Contact IDSY

[FUNCTIONAL] VAC hardware is for a different region (North America, EMEA, APAC).

#### Action

- If this occurs, the VAC must be replaced with a region appropriate VAC.

## Other Error Codes

“Error: 00” through “Error: 37” [displayed at any time without warning to any operator type] – These errors may allow vehicle use during the error and may self-correct. Intermittent display of the same error, or recurring errors should be considered an issue.

Possible Cause(s)	Action
One-time VAC issue	None for Operators. The VAC self-re-boots until the error is cleared.
Intermittent or continuous VAC issue	<ul style="list-style-type: none"><li>• Request an RMA (See Appendix A)</li><li>• Call Powerfleet’s Customer Service for an RMA number.</li><li>• Only the VAC should be returned for analysis/repair.</li><li>• Once the VAC is removed, the system MUST be hard bypassed to use the vehicle.<ul style="list-style-type: none"><li>○ Follow instructions on how to hard-bypass the system. (See Appendix B)</li></ul></li></ul>

### 80-Vehicle Soft Bypassed (Refer to Hardware Guide)

[REFERENCE] The vehicle system has been placed in “ID Optional” mode. This error will not display on the vehicle, only in the error reports from the software.

Possible Cause(s)	Action
A Maintenance operator placed the vehicle in “ID Optional” mode	<ul style="list-style-type: none"><li>• Log into the vehicle as a Maintenance operator.</li><li>• Select the <i>Access</i> menu option, and then press ENTER.</li><li>• On the “Access” sub-menu, select the <i>Settings</i> menu option, and press ENTER.</li><li>• On the “Settings” sub-menu, select “Registered IDs” to disable soft bypass and restore vehicle access control. Operators will again be required to log in to use the vehicle.</li></ul>

### 81-Vehicle Not Detected in N Days (Refer to Hardware Guide)

[REFERENCE] The vehicle has not communicated with the software in N days, where N is calculated based on the last communication date. This error will not display on the vehicle, only in the error reports from the software.

Possible Cause(s)	Action
VAC communication	<ul style="list-style-type: none"><li>• Drive the vehicle near the Wireless Asset Manager (WAM), or Access Point for Wi-Fi systems, and wait 1-30 minutes.</li></ul>
VAC error	<ul style="list-style-type: none"><li>• Verify that other VACs synchronize with the system correctly by driving another vehicle near the Wireless Asset Manager (WAM) or Wi-Fi Access Point, waiting 2 minutes, then checking the “Vehicle Configuration Status” report in Powerfleet Vision Pro software to verify Last Detected Date is the current date.</li><li>• If other VACs are synchronizing<ul style="list-style-type: none"><li>○ Request an RMA (See Appendix A)</li><li>○ Call Powerfleet’s Customer Service for an RMA number.</li><li>○ Only the VAC should be returned for analysis/repair.</li><li>○ Once VAC is removed, the system MUST be hard bypassed to use vehicle.</li><li>○ Follow instructions on how to hard-bypass the system. (See Appendix B)</li></ul></li><li>• Run “CloneVAC” on the new VAC (See Section 4 for instructions)</li></ul>

WAM/Modem communication	<ul style="list-style-type: none"> <li>• Verify that the WAM and Modem LEDs match the recommended state. Refer to the WAM Installation QuickStart Guide.</li> <li>• If the LEDs do not match the recommended state, reboot the WAM by unplugging the WAM, waiting 30 seconds and plugging the WAM back in. Verify that the WAM and Modem LEDs match the recommended state. Refer to the WAM Installation QuickStart Guide.</li> <li>• If rebooting the WAM does not work <ul style="list-style-type: none"> <li>○ Request an RMA (See Appendix A) <ul style="list-style-type: none"> <li>○ Call Powerfleet’s Customer Service for an RMA number.</li> </ul> </li> </ul> </li> <li>• Only the WAM should be returned for analysis/repair.</li> </ul>
Wi-Fi communication	<ul style="list-style-type: none"> <li>• Verify the VAC is connected to the server.</li> <li>• Update the Wi-Fi connection profile (SSID, Security method, credentials, etc.)</li> <li>• Turn the Wi-Fi off.</li> <li>• Turn the Wi-Fi on.</li> <li>• If the VAC still does not communicate and the Wi-Fi status indicator displays no bars: <ul style="list-style-type: none"> <li>○ Request an RMA (See Appendix A)</li> <li>○ Call Powerfleet’s Customer Service for an RMA number.</li> <li>○ Only the WAM should be returned for analysis/repair.</li> </ul> </li> </ul>

### 82-Vehicle Delayed Sync (Refer to Hardware Guide)

[REFERENCE] Certain data on the VAC is not up to date. This error will not display on the vehicle, only in the error reports from the software.

Possible Cause(s)	Action
VAC communication	<ul style="list-style-type: none"> <li>• Drive the vehicle near the Wireless Asset Manager (WAM), or Access Point for Wi-Fi systems, and wait 1-30 minutes.</li> </ul>
VAC error	<ul style="list-style-type: none"> <li>• Verify that other VACs synchronize with the system correctly by driving another vehicle near the Wireless Asset Manager (WAM) or Wi-Fi Access Point, waiting 2 minutes, then checking the “Vehicle Configuration Status” report in Powerfleet Vision Pro software to verify Last Detected Date is the current date.</li> <li>• If other VACs are synchronizing <ul style="list-style-type: none"> <li>○ Request an RMA (See Appendix A)</li> <li>○ Call Powerfleet’s Customer Service for an RMA number.</li> <li>○ Only the VAC should be returned for analysis/repair.</li> <li>○ Once VAC is removed, the system MUST be hard bypassed to use vehicle.</li> <li>○ Follow instructions on how to hard-bypass the system. (See Appendix B)</li> </ul> </li> <li>• Run “CloneVAC” on the new VAC (See Section 4 for instructions)</li> </ul>

WAM/Modem communication	<ul style="list-style-type: none"> <li>• Verify that the WAM and Modem LEDs match the recommended state. Refer to the WAM Installation QuickStart Guide.</li> <li>• If the LEDs do not match the recommended state, reboot the WAM by unplugging the WAM, waiting 30 seconds and plugging the WAM back in. Verify that the WAM and Modem LEDs match the recommended state. Refer to the WAM Installation QuickStart Guide.</li> <li>• If rebooting the WAM does not work <ul style="list-style-type: none"> <li>○ Request an RMA (See Appendix A)</li> <li>○ Call Powerfleet’s Customer Service for an RMA number.</li> </ul> </li> <li>• Only the WAM should be returned for analysis/repair.</li> </ul>
Wi-Fi communication	<ul style="list-style-type: none"> <li>• Verify the VAC is connected to the server.</li> <li>• Update the Wi-Fi connection profile (SSID, Security method, credentials, etc.)</li> <li>• Turn the Wi-Fi off.</li> <li>• Turn the Wi-Fi on.</li> <li>• If the VAC still does not communicate and the Wi-Fi status indicator displays no bars: <ul style="list-style-type: none"> <li>○ Request an RMA (See Appendix A)</li> <li>○ Call Powerfleet’s Customer Service for an RMA number.</li> <li>○ Only the WAM should be returned for analysis/repair.</li> </ul> </li> </ul>

**83-Impact sensor Er (Refer to Hardware Guide) [last X, Y reading]**

[FUNCTIONAL] The impact sensor has experienced a hardware/connection error.

Possible Cause(s)	Action
Disconnected impact sensor	<ul style="list-style-type: none"> <li>• Verify that impact sensor is installed on the specified vehicle. If not, and it is uninstalled intentionally, then you must either re-run Install Wizard (to disable sensing at the VAC) or disable Impact Sensing for that vehicle using Powerfleet Vision Pro.</li> <li>• If the sensor is present but unplugged, then plug sensor back in. Identify how it was disconnected and address the root cause (e.g., no service loop/pulled too tight; cable connector cover missing on VAC Bracket, etc.)</li> <li>• Verify that sensor is working using the Hardware-&gt;Impact screen. X/Y readings should be 0.0 +/- 0.2G with R readings between 70 and 90 on both axes. If not, sensor may be malfunctioning.</li> </ul>

Malfunctioning impact sensor

- If X or Y reading is non-zero, but also not between 70 and 90, the sensor may be malfunctioning; also, if X or Y is normal (70-90) but the other axis is 0, then sensor is malfunctioning.
- Request an RMA (See Appendix A)
- Mounting using screws or non-IDSY-provided tape; Re-mount using provided tape.
- Make sure that no other object is 'bouncing' on top of sensor during normal driving.
- Make sure that mounting location avoids positioning right near vehicle wheels or other surfaces prone to repetitive vibration while driving.
- Call Powerfleet’s Customer Service for an RMA number.
- Only the impact sensor should be returned for analysis/repair.
- Once the impact sensor is removed, the system will display error #13. This error can be ignored until the impact sensor is replaced.

## 10 SECTION 10: SYSTEM SUPPORT INFORMATION

### 10.1 Technical Specifications – VAC4S and VAC4

#### Electrical Specifications

Power Interface	Min	Nominal	Max
Rated, operating supply voltage (VDC) – I/C or Electric	9	-	99
Internal Fuse (A) [non-serviceable]	-	3	-
External In-Line Fuse (A)**	-	2	-

\*\*Pre-installed in wiring harness; spare available in Site Kit

Vehicle Current Draw	VAC4S			VAC4		
	Hibernate	Nominal	Max	Hibernate	Nominal	Max
12 Volt Source (mA)	18	250	280	50	350	550
24 Volt Source (mA)	15	110	130	30	200	300
36 Volt Source (mA)	12	80	100	25	140	200
48-, 60-, or 72-Volt Source (mA)	10	55	80	20	100	140

Access Control Interface	VAC4S			VAC4		
	Min	Nominal	Max	Min	Nominal	Max
Output Voltage (VDC) <i>[coil connection]</i>	9	12	12	11.5	12	12
Duty Cycle for PWM P-Plug connection 25% = Novice skill level 50% = Intermediate skill level 75% = Expert skill level 100% = Unsafe Event active	9	12	12	-	-	-

#### Processor/Memory/Other Specifications

Item	VAC4S	VAC4
Processor	32-bit Microprocessor @ 180 MHz	32-bit Microprocessor @ 60 MHz
RAM	2 MB x 16 + 256K on chip	4 MB x 16
RAM type	Battery-backed SRAM	Battery-backed SRAM
External Flash	64 MB	-
On chip Flash	2 MB	2 MB x 16
Real-time clock	Onboard, 1 sec/day accuracy, updated automatically via RF	
Utilization history storage (RAM)	Approx. 1 month	
Location history storage (RAM)	Approx. 10 days	

## Communication Specifications

Intelligent RF Protocol	Min	Nominal	Max
Frequency (MHz) - US	902.6	915	927.4
Frequency (MHz) - EU	868.3	868.3	869.85
Output power (mW)	0.1	25	250*** (US) 500*** (EU)
Modulation	-	FSK, DTS, Narrow band	-
Frequency Agility	-	26 Adjustable channels (US) 868.3, 868.95, 869.525, or 869.85 MHz (EU)	-
Communication Data Rate (Kbps) - US	78	156	156***
Communication Data Rate (Kbps) - EU	19	156	156***
Communication Scheme	-	CSMA/CD (US); CSMA/CD/LBT (EU)	-
Antenna	-	Internal PCB antenna, omni-directional	-

\*\*\* Depends on channel utilized

Wi-Fi	
Protocols supported	802.11 a, b, g, n
Frequency (GHz)	2.412-2.484 GHz; 5.18-5.32 GHz; 5.5-5.825 GHz
Channels	US: 1-11; EU: 1-13; JPN: 1-14; US/EU: 36-64; 100-165
Modulation	DSSS
Bandwidth	20/40 MHz
Transceiver Power	+18 dBm
Receiver Sensitivity	-97 dBm
Antenna	Internal antenna, omni-directional
WLAN security setting options	Open, WEP-64, WEP-128, WPA-PSK (TKIP), WPA2-PSK (AES),

Wi-Fi	
	WPA-EM (PEAP-MSCHAPv2), WPA2-EM (PEAP-MSCHAPv2)
Data Encryption	TLS1.2 in transit

Bluetooth	
Protocols supported	Bluetooth 4.0 (2.1+EDR, LE)
Frequency	2402 MHz - 2480 MHz
Channel Spacing	BR, EDR – 1 MHz; LE – 2 MHz
Modulation	GFSK, DQPSK, 8DPSK
Transceiver Power	15 dBm (Class-1)
Receiver Sensitivity	-94 dBm

### User Interface Specifications

User Interface - VAC	Specification
Keypad – type	Membrane/polyester; 20 keys
LCD – display type	DFSTN, black/white; 132 x 64 pixels
Backlight	White LED
Status LEDs – See below	4, integrated, 270° viewable from 50'
Environmental Spec	IP67

iButton	Specification
iButton Type	DS19
Reader Location	External/Bottom edge mount

Proximity Card	Specification
Proximity Card Type	HID only (VAC4) or Multi-Prox (50+ protocols; 125 KHZ or 13.65 MHz – VAC4S)
Proximity Reader Location	Internal / tamperproof

### Mounting Specifications

VAC	Specification
Electrical considerations	Isolation from chassis required (and provided)
Mounting method	2 x M6 screws or bolts (supplied)
Mounting holes	2 x ¼" dia. holes for bracket, 1x 1.25" dia. round hole for cable

### Sensor Specifications

Motion Sensing (wired)	Specification
Electric vehicle connection	<b>Avg:</b> average DC or 'AC' square-wave duty-cycle monitoring (BLU Wire) <b>Min/Max:</b> peak-to-peak (BLU Wire)
Internal Combustion vehicle connection	Engine on and in-gear (BRN and BLU wires)

Motion, Lift motor, Seat/Deadman Sense Criteria	Min	Nominal	Max
Voltage Range (Electric vehicle)	0	B+ (battery positive)	100
Voltage Differential – Idle/Motion (Electric vehicle; BLU wire)	1.0†	20	100
Voltage Range (Internal combustion vehicle)	0	B+	100
Voltage Differential Idle/Motion (IC vehicle; BRN and BLU wires)	1.0†	B+	20

†Voltage differential between motion state and idle state must be at least 1.0 volt

Impact Sensor	Min	Nominal	Max
Impact Range (G)	1	11	11
Axes	-	X, Y only	-
Threshold configuration	Auto-configuring; manual threshold settings not required		

GPS Receiver	Specification
Manufacturer Details	US Global Sat model BR-355-S4
Chipset / Protocol	SiRF Star IV / NMEA 0183 (default) or siRF binary (alternate)
Accuracy	Less than 2.5 m (< 8.2 ft) 2D RMS SBAS Enabled
Acquisition rate (averages)	Hot start = 1 sec; warm or cold start = 35 sec
Mounting	Integrated bracket via tape, or screws
Location Update Rate	1 Hz

Output Alert	Specification
2-wire Voltage Control Output	0 or 12 VDC output (typically for strobe light, sounder, or vehicle horn)

Fork Load Sensor	Min	Nominal	Max
Hydraulic pressure range (PSI)	0	1000	5000
Installation	Common range of JIC 37° Flare and ORFS fittings		

Tow/Dolly Sensor	Min	Nominal	Max
Proximity/Distance Range	6"	24"	39"
Mounting	Rear of tow vehicle, near tow-load hitch		

## Regulatory and Product Certifications

Certification	Specification
UL / cUL	UL 60950-1 / CSA C22.2 NO. 60950-1, UL583, UL558
CE	EN12895:2015+A1:2019, EN301489-1:v2.2.3(2019), EN301489-3:v2.3.2(2023), EN301489-17:v3.2.6(2023), EN300220-1/-2:v3.2.1(2018), EN300328:v2.2.2(2019), EN300330:v2.1.1(2017), EN301893:v2.1.1(2017), EN303413:v1.2.1(2018), EN55032:2015+A11:2020, EN55035:2017+A11:2020, EN62368-1+A11(2020), IEC62311:2020, IEC62368-1:2018(3 <sup>rd</sup> version)
ETSI	EN 300 489-1/3, EN 300 220-1, EN 300 328
EMC	2014/30/EU
RED	2014/53/EU
LVD	2014/35/EU
FCC	<p>US FCC: 47 CFR Part 15, Industry of Canada RSS-247</p> <p>These limits are designed to provide reasonable protection against harmful interference when the equipment is operated in a commercial environment. This equipment generates, uses, and can radiate radio frequency energy and, if not installed and used in accordance with FCC instructions, may cause harmful interference to radio communications. However, there is no guarantee that interference will not occur in a particular installation. If this equipment does cause harmful interference to radio or television reception, which can be determined by turning the equipment off and on, the user is encouraged to try correcting the interference by one or more of the following measures:</p> <ol style="list-style-type: none"> <li>1.1. Reorient or relocate the receiving antenna,</li> <li>1.2. Increase the separation between the equipment and receiver.</li> <li>1.3. Connect the equipment into an outlet on a circuit different from that to which the receiver is connected.</li> <li>1.4. Consult the dealer or experienced radio/TV technician for help.</li> </ol>

## Environmental Specifications

VAC	Specification
Operating Temperature*	-40 C to +85 C (screen not visible below -32 C)
Storage Temperature*	-40 C to +85 C
Humidity	MIL-STD-810F, Method 507.4, 95% RH (non-condensing)
Environmental Sealing	Exceeds NEMA 3R, Mil-Std-810E Method 506.3 Procedure III; IP67
Vibration	MIL-STD-810F, Method 514.5 (12.35Grms random vibration), heavy duty truck chassis mount
Shock	MIL-STD-810F, Method 516.5, Procedure I (20 G Functional), V (40 G Crash Hazard)
Drop (product)	3 ft onto Concrete; 1 per side

Altitude	MIL-STD-810F, Method 500.4, Section II (Operations/Air Carriage) – 15,000 ft
Solar	MIL-STD-810F, Method 505.4, Procedure II (Cyclic)
Thermal Shock	MIL-STD-810F, Method 503.4, Procedure II (Cyclic), -40C ↔ +70C
Salt Fog	MIL-STD-810F, Method 509.4
ESD	+/- 8kV contact; +/- 15kV non-contact

\* Prolonged exposure to temperatures above 70° C may affect keypad tactile response.

# 11 Appendix A: Customer Support and Return Merchandise Authorization (RMA) Policy & Procedures

## 11.1.1 Customer Support & RMA Information

---

Technical Support/RMA: Tel +1.201.690.7011

Support Hours: 9:00am - 6:00pm, Monday - Friday (Eastern)

An RMA number can be requested 24 / 7 (Excluding Holidays)

## 11.1.2 RMA Procedure

---

**Step 1:** Troubleshoot with a Powerfleet Support member.

Supply the End User's company name, city, and state/province. Identity your role: End User, Dealer, or 3rd Party Service representative.

**Step 2:** Request an RMA

In the event the hardware requires repair, please email the RMA details listed below to [RMA@powerfleet.com](mailto:RMA@powerfleet.com):

- End User's company name, city, and state/province.
- Device Description
- Part Number (see Locating Part Numbers on the following pages)
- Device Serial Number
- Description of failure - primary symptoms or issue
- Shipment Information (address and contact info)
- PO Approver - in the event there is hardware damage, who should receive the quotation

**Step 3:** Return the RMA to Powerfleet

Upon receipt of an RMA number, package the material and return it to Powerfleet. Material cannot be returned to Powerfleet without an RMA already assigned. The shipping address is supplied as part of the automated RMA e-mail notice.

**Step 4:** Evaluation and Damage Determination

In the event the repair requires a purchase order to proceed, Powerfleet will send the quotation for repair to the PO approver defined in Step 1. The RMA hardware will remain on hold until the PO Approver provides additional direction. If there is no response from the PO Approver, we will return the hardware after 90 days.

## **Step 5: Repair and Return**

Once the RMA hardware is repaired, it will be returned using the shipping information identified in Step 2.

### **Additional Terms**

- If the product is covered under the warranty, the repair work will be completed without the customer's consent. If the product is no longer covered under the warranty, an estimate of the repair, shipping and handling costs will be provided to the customer. Upon receipt of a PO or credit card number, the hardware will be repaired and shipped back to the customer. If a PO or credit card number is not provided, the devices may be returned unrepared.
- Please be sure to ship the item(s) requiring a signature upon delivery. All packages must be shipped to Powerfleet, Inc. as freight prepaid.
- Items will be tracked according to the RMA number, so please be sure to include this number on the outside of the box, as well as on a label that is affixed to the unit(s). Any customer that does not note the RMA number on the box may be subject to a service charge and the product will be kept in a holding area until the discrepancy is resolved.

## 12 Appendix B (Hard Bypass Powerfleet access control)

### 12.1.1 Refer to the Powerfleet Installation Guide for detailed wiring diagrams.

#### Hard-bypassing access control

You must open the vehicle and have access to the Powerfleet relay circuit to complete this procedure. Depending on the access control relay you are using, the connection points may differ:

For relays with embedded spade terminals:

- a. Remove any wires connected to the #2 and #4 positions on the access control relay and connect those wires (#2 and #4) to each other.
- b. Remove any wires connected to the #6 and #8 positions on the access control relay and connect those wires (#6 and #8) to each other.

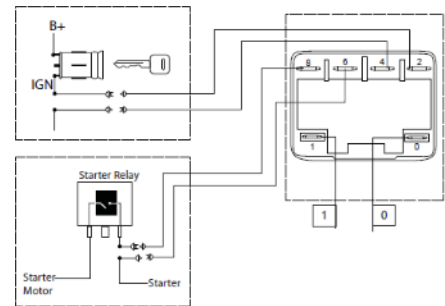

For relays with orange and grey wire connections:

- a. Remove any wires connected to the orange wires of the access control relay and connect those wires to each other.
- b. Remove any wires connected to the grey wires of the access control relay and connect those wires to each other.



- 3 OEM custom vehicle harnesses only, perform the following:

#### iPort Connector:

- a. Disconnect the iPort cable harness from the vehicle connector and disable the iPort feature on the Vehicle Manager (for more information, contact your Vehicle Manufacturer representative).

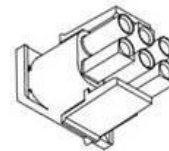

iPort Connector

#### Still/Linde/Jungheinrich JPT Connector:

- a. Disconnect the JPT cable harness from the vehicle connector.
- b. Connect the VMS bypass bridge to the Still/ Linde/ Jungheinrich JPT connector.



Still/Linde/  
Jungheinrich JPT  
connector

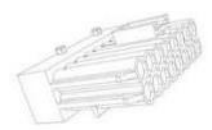

VMS Bypass  
Bridge

#### VDI and P-Plug Connectors

- a. Disconnect the VDI cable harness from the vehicle connector and disable the VDI feature on the Vehicle Manager (for more information, contact your Vehicle Manufacturer representative).

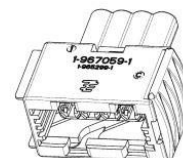

VDI Connector

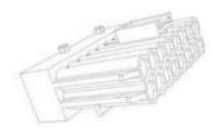

P-Plug  
Connector

## 13 Appendix C (Using the Powerfleet Wi-Fi Test Tool)

### 13.1.1 POWERFLEET'S WI-FI TEST TOOL.

THERE ARE TWO TEST TOOLS AVAILABLE. THE SMART PHONE APP (SEARCH "VMS TOOLS" IN THE ITUNES OR GOOGLE PLAY APP STORES) IS THE PREFERRED METHOD. A PC-BASED VERSION IS ALSO AVAILABLE THROUGH THE I.D. SYSTEM CUSTOMER PORTAL (or email [support@powerfleet.com](mailto:support@powerfleet.com)).

#### SMARTPHONE APP TEST TOOL

1. Download and install the app.
2. Register and login to the app.
3. Select Wi-Fi Test from the bottom of the VMS Tools APP Home screen.
4. Make sure the mobile phone you are using is connected to the Wi-Fi network the vehicles will connect to.
5. From Wi-Fi Test, click Next.
6. Place the cursor in the field displayed as Click here to select Customer Site
7. Select the Customer Site and click Next.
8. Enter IP Address & Port number provided, click Start Test
  - a) Wi-Fi Test Passed results displays Test Completed Successfully
  - b) Wi-Fi Test Failed results displays Test Failed. The Port or IP address is being blocked. If the Wi-Fi Test Failed, contact your system administrator for support to connect to Wi-Fi network.

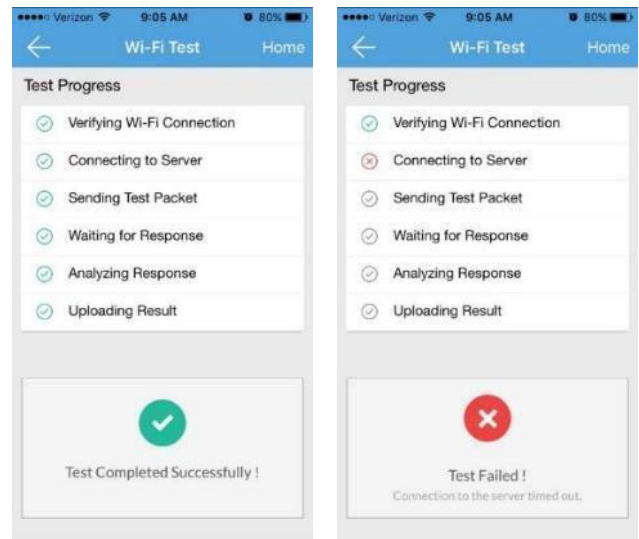

#### PC/Laptop-BASED TEST TOOL

1. Download the **Vision.Pro.Emulator\_r2.zip** file ([Wi-Fi Test Tool Download](#)) to a Wi-Fi capable PC (or Laptop).
  - a. **NOTE:** You may receive a notice stating the content is read only. Regardless of the notice, proceed by clicking the  **Download** link.
  - b. Save the zip file to your desktop.
2. Unzip the executable to a location on a Wi-Fi capable PC/Laptop.
3. Connect the PC to the **same wireless network** the VACs connect to. Double-check the PC is NOT also connected to the network via Ethernet.
4. Confirm the connected device obtains an IP address that falls into the same range that the VACs are using, if planning to use Static IPs.

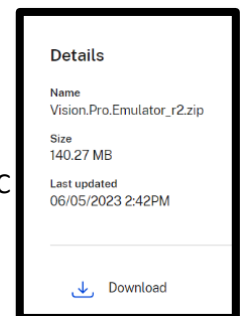

5. If the device's IP address does not fall into the same range that the VACs use, the rest of the test steps will be invalid. Your IT department should ensure the device IP address is in the range assigned to the VACs.
6. Once unzipped, click the publish folder. Open and run the VisionPro.WifiTool.WinForm.exe file. Do not remove, move, or edit any other folders/files, or the test tool may not open.
7. You may be prompted with a warning: "The publisher could not be verified. Are you sure you want to run this software?" Click (or then [More info](#) [Run anyway](#) for Windows 10). Enter the following information in the Wi-Fi Test Configuration tab:

PWFL Hosted Sites			
<b>IP Address</b>	216.250.138.155 (USA customers only) Other customers: provided by Powerfleet; contact Support if needed.	<b>Count of simple messages / minutes</b>	10
<b>Port</b>	Provided by Powerfleet; contact Support if needed. Do not include punctuation.	<b>Test Duration (minutes):</b> (Should the test fail at 1 minute try increasing up to 5 minutes.)	1
<b>Facility ID</b>	Provided by Powerfleet; contact Support if needed. Do not include punctuation.	<b>Advanced messages per minute</b>	0
<b>Encryption</b>	<b>Only Check if the port is between: 40000-49999.</b>	<b>(Source Address) IP Address</b>	192.168.1.92 Use the default
		<b>(Source Address) Port</b>	Leave Blank

The screenshot shows a configuration window with the following sections:

- Destination server (COMM UDP):** IP address: 216.250.138.155, Port: 55087, Facility ID: 2049.
- Encryption:**  Enable encryption.
- VAC Message Profile:** Count of simple messages / min: 10, Advanced messages per minute: 0, Test Duration (minutes): 1.
- Source address:** IP address: 192.168.1.92, Port: (empty field).

8. Go to the **Output tab**.
9. Check the **Enable output checkbox**.
10. Click the **Start Wi-Fi Test button**.
  - a. The test is complete when the log reads: "**Sending finished: XXX.XXX**"
  - b. The screen shot indicates communication between the site's Wi-Fi network and the server software is working properly.

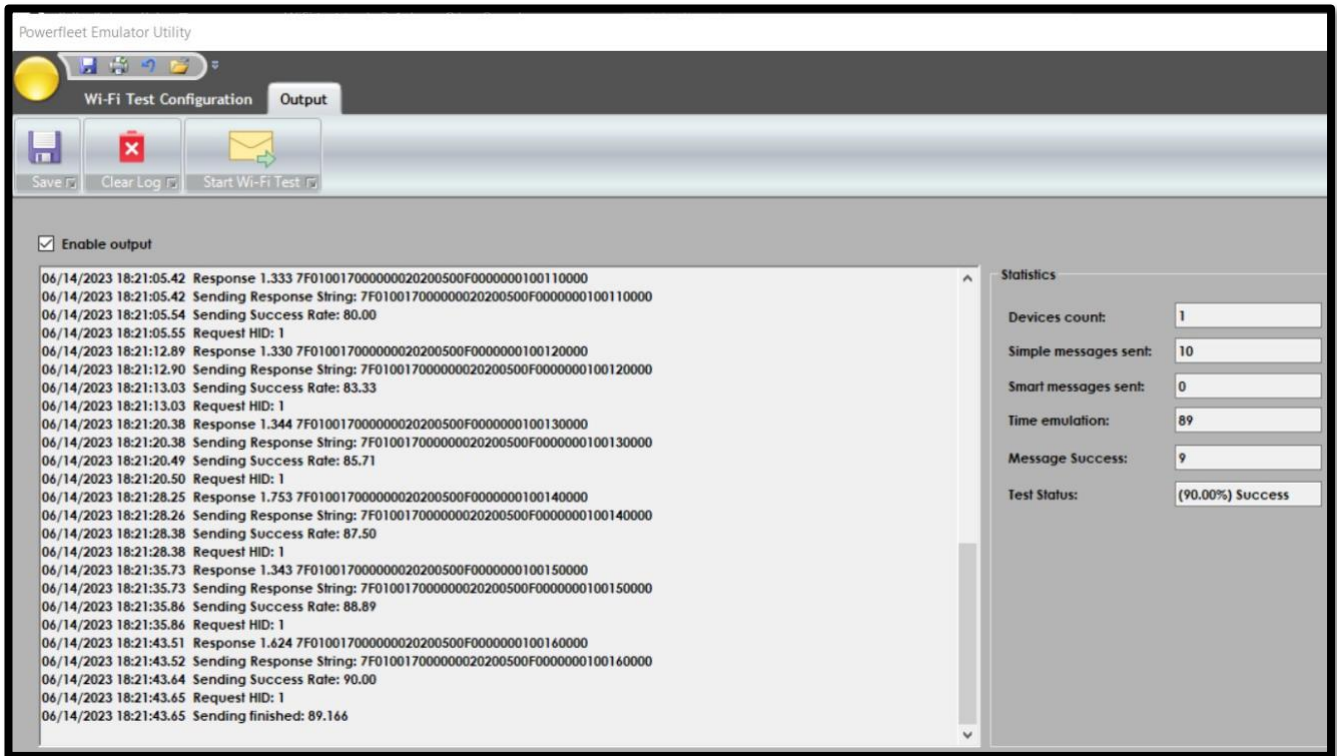

If you do not receive a **(XX.XX% Success)** result, the test **was unsuccessful**. Click the **Save** button to save the log file. Then click the **Clear Log** button, return to the **Wi-Fi Configuration** tab, and set the **Test Duration** up to 5 minutes. If you continue to get failed-test results, there may be an issue with the integrity of the connection to the server. The site's IT should verify the AP logs, firewalls, etc. to confirm why the connection cannot be reached.

**NOTE:** You can receive a **Success** with a percentage less than 100%.

If you receive a `mswinsck.ocx` error while running this test, please contact [support@powerfleet.com](mailto:support@powerfleet.com) for our other testing method – iOS smartphone app.

For passing tests, send a test screen capture to [support@powerfleet.com](mailto:support@powerfleet.com).

For failing tests, send a test screen capture and a **full Word/Notepad** copy of the log to [support@powerfleet.com](mailto:support@powerfleet.com).

The test log can also be saved and emailed.

Please set the email's subject to **"Wi-Fi test tool results"**.